

# METAL AM



**in this issue**

**METAL AM SOFTWARE FOCUS**

**EOS: ADDITIVE MINDS**

**WORLD PM2016 TECHNICAL REPORTS**



**TruForm™**  
Metal Powders  
for Additive Manufacturing



# Making your DREAMS for metal AM FLY

**With Praxair powders, the sky isn't the limit**

Look to Praxair Surface Technologies for the metal powders, know-how, resources and supply to turn your AM dreams into reality.

- Approved aerospace grade
- Large lot sizes and R&D volumes
- Stock availability and custom offerings

**IT'S TIME TO DREAM BIG.**

[praxairsurfacetechologies.com/am](http://praxairsurfacetechologies.com/am)

Contact us to find out how we are making more possible:  
**1-317-240-2650 or [praxair\\_am@praxair.com](mailto:praxair_am@praxair.com)**

**PRAXAIR**  
SURFACE TECHNOLOGIES

© Copyright 2017 Praxair S.T. Technology, Inc. All rights reserved.

# METAL ADDITIVE MANUFACTURING

## Software solutions key to application development

When it comes to metal Additive Manufacturing it can be all too easy to overlook the impact that software can have on the success or failure of a new application or venture. Yes, you really want that new machine to get building your part and there's no shortage of materials suppliers willing to help fill the build chamber. However, there is a sense that not many new entrants into the industry are fully aware of just how much the latest software solutions can help influence the development of a component.

For newcomers to the industry, the pressures to progress that first application come from all sides. A lack of experience works against you and, as time goes by, the inevitable build failures have a very high cost. This cost can be in terms of lost machine time, wasted materials, machine damage and, last but not least, a slow but steady erosion of confidence in the technology by your colleagues and management.

In this issue of *Metal AM* magazine two leading AM software providers, Autodesk and Materialise, explain how their latest software solutions help speed up the application development cycle through distortion simulation and innovative part orientation and support technologies.

It is clear that such software solutions have the potential to dramatically reduce the number of build failures in metal AM and can help make the 'trial-and-error' approach to part development a thing of the past.

Nick Williams  
Managing Director



**Cover image**  
*Metal Additive Manufacturing at Materialise's Bremen production facility [Courtesy Materialise]*

### Publisher & Editorial Offices

Inovar Communications Ltd  
2 The Rural Enterprise Centre  
Battlefield Enterprise Park  
Shrewsbury SY1 3FE, United Kingdom  
Tel: +44 1743 454990  
Fax: +44 1743 469909  
Email: [info@inovar-communications.com](mailto:info@inovar-communications.com)  
[www.metal-am.com](http://www.metal-am.com)

### Managing Director, Features Editor

Nick Williams  
Tel: +44 1743 454991  
Email: [nick@inovar-communications.com](mailto:nick@inovar-communications.com)

### Publishing Director, News Editor

Paul Whittaker  
Tel: +44 1743 454992  
Email: [paul@inovar-communications.com](mailto:paul@inovar-communications.com)

### Advertising

Jon Craxford, Advertising Sales Director  
Tel: +44 207 1939 749  
Fax: +44 1743 469909  
Email: [jon@inovar-communications.com](mailto:jon@inovar-communications.com)

### Production

Hugo Ribeiro, Production Manager  
Tel: +44 (0)1743 454990  
Fax: +44 (0)1743 469909  
Email: [hugo@inovar-communications.com](mailto:hugo@inovar-communications.com)

### Subscriptions

*Metal Additive Manufacturing* is published on a quarterly basis as either a free digital publication or via a paid print subscription. The annual print subscription charge for four issues is £95.00 including shipping. Rates in € and US\$ are available on application.

### Accuracy of contents

Whilst every effort has been made to ensure the accuracy of the information in this publication, the publisher accepts no responsibility for errors or omissions or for any consequences arising there from. Inovar Communications Ltd cannot be held responsible for views or claims expressed by contributors or advertisers, which are not necessarily those of the publisher.

### Advertisements

Although all advertising material is expected to conform to ethical standards, inclusion in this publication does not constitute a guarantee or endorsement of the quality or value of such product or of the claims made by its manufacturer.

### Reproduction, storage and usage

Single photocopies of articles may be made for personal use in accordance with national copyright laws. All rights reserved. Except as outlined above, no part of this publication may be reproduced, modified or extracted in any form or by any means without prior permission of the publisher and copyright owner.

### Printed by

Cambrian Printers, Aberystwyth, UK  
ISSN 2057-3014 (print edition)  
ISSN 2055-7183 (digital edition)  
Vol. 3. No. 1 Spring 2017

**This magazine is also available for free download from [www.metal-am.com](http://www.metal-am.com)**

© 2017 Inovar Communications Ltd

# AncorAM™

Metal Powders for Additive Manufacturing



GKN Hoeganaes, a world leader in the development of metal powders, has been the driving force behind the growth in the Powder Metallurgy industry for over 65 years. GKN Hoeganaes has fueled that growth with successive waves of technology, expanding the use of metal powders for a wide variety of applications.

## AncorTi™

- Spherical Titanium Powder for Additive Manufacturing
- Particle Size Engineered for Selective Laser Melting (SLM) and Electron Beam Melting (EBM)
- Rigorous Quality Testing



FOLLOW US ON SOCIAL MEDIA AT:

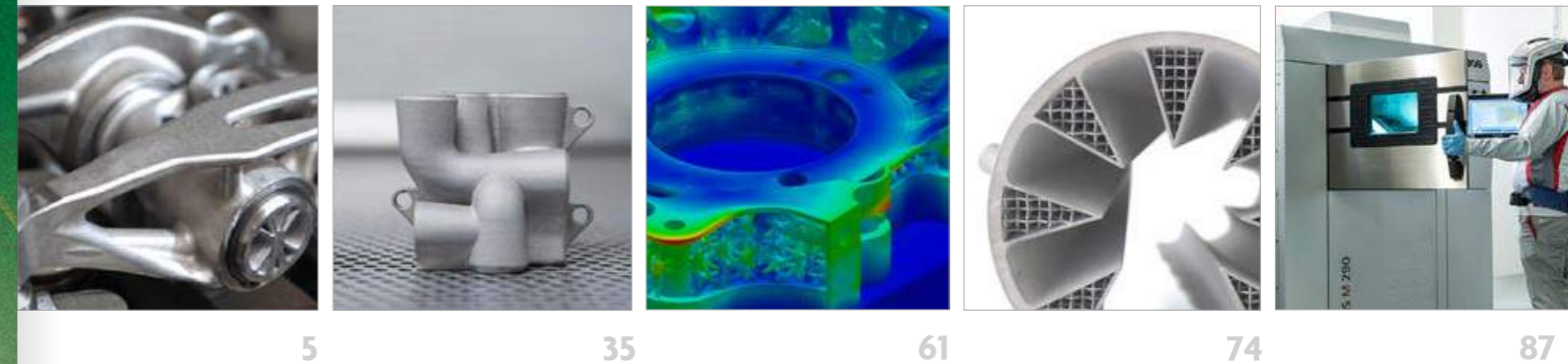

## Contents

- 5 Industry News**
- 61 Distortion in metal Additive Manufacturing: Modelling and mitigation**  
Autodesk's Michael Gouge and Pan Michaleris explain how software can now quickly and accurately simulate distortion in metal AM, significantly reducing build failure rates, minimising the associated economic impact and enhancing the technology's reputation.
- 73 Materialise Magics: Advanced part orientation and support solutions to speed up application development**  
Kirsten Van Praet reveals how the latest release of the Materialise Magics suite helps users achieve higher levels of AM production success through advanced part orientation and support solutions. Advantages of the metal AM process are also reviewed through various application examples.
- 83 EOS GmbH: Transforming companies into AM champions with Additive Minds**  
The launch of EOS's Additive Minds service represents a significant expansion of the support that the company can offer to those entering the industry. We talk Güngör Kara about the evolution of metal AM and the changing approach that customers are taking to implement the technology.
- 91 The science behind a basic consumer product: Bottle openers by metal AM**  
In the first of a new series of articles for Metal AM magazine, Olaf Diegel and Terry Wohlers reveal how bottle openers demonstrate several key concepts that designers need to understand in the development of parts for production by metal AM.
- 97 Accelerating AM component design workflow with new optimisation technology**  
LimitState's Prof Matthew Gilbert reveals how a new optimisation approach means that engineers can now directly identify optimised truss forms for AM components, saving time and effort.
- 101 Opportunities for AM with water atomised metal powders**  
We review two papers from the World PM2016 Congress that assess the viability of the water atomisation process for the production of powders for AM.
- 109 Extending the range of materials in Powder Bed Fusion AM**  
We report on papers from the World PM2016 Congress that addressed Inconel 625 superalloy produced by EBM, Metal Matrix Composites with ceramic reinforcement and the Additive manufacturing of zinc.
- 119 Events guide**
- 120 Advertisers' index**

# CONCEPTLASER

## MACHINE SOLUTIONS FOR ADDITIVE MANUFACTURING WITH METALS

Source: LaserCUSING® LAC – Laser Add Center GmbH  
Machine layout & Rendering: newkon.info  
Photos: finamedia.de, uwe-muehlhaeusser.de  
Artwork: brandnew-design.de



**NEW!**

SEE YOU AT **International Dental Show**  
**Cologne, Germany** | 21. – 25.03.2017  
Hall 10.1 | Booth B034

[www.concept-laser.de](http://www.concept-laser.de)

**Concept Laser GmbH** An der Zeil 8 | D 96215 Lichtenfels  
T: +49(0)9571.1679 200 | F: +49(0)9571.1679 299 | [info@concept-laser.de](mailto:info@concept-laser.de)

# industry news

## Renault Trucks: Metal Additive Manufacturing could reduce engine weight by 25%

A team of Renault Trucks engineers and designers is looking to metal Additive Manufacturing to boost the performance of its engines. The Renault Trucks Lyon Powertrain Engineering department has focused on using the technology as a future engine manufacturing process, resulting in a prototype DTI 5 4 - cylinder Euro-6 step C engine being designed exclusively using Additive Manufacturing.

Renault has reported that rocker arms and camshaft bearing caps were manufactured by metal AM and successfully bench-tested for 600 hours inside a Euro-6 engine.

"The aim of this project is to demonstrate the positive impact of metal Additive Manufacturing on the size and weight of an engine. This process has enabled us to reduce the weight of a 4-cylinder engine by 120 kg or 25%," stated Damien Lemasson, project manager at Renault Trucks. "The tests we have carried out prove the durability of engine components made using 3D printing. It's not just cosmetic."

Metal Additive Manufacturing is opening up new opportunities for engine manufacturers. The process allows engineers to optimise the size of parts, reducing the number of assembly operations and therefore the number of components in an engine. In the short-term, this manufacturing procedure can be used for highly specific applications or small runs.

"Additive Manufacturing releases us from constraints and unlocks

the creativity of engineers," added Lemasson. "This procedure is a source of disruptive technology for the engines of tomorrow, which will be lighter and more functional, thereby offering optimal performance."

The number of components in the DTI 5 engine has been reduced by 25%, making a total of 200 fewer parts. Following on from these successful initial tests, engineers at Renault Trucks will be continuing their work on this manufacturing process to further increase the performance and functionality of truck components

[www.corporate.renault-trucks.com](http://www.corporate.renault-trucks.com) ■■■



The re-designed metal AM version of the rocker arm is shown during a bench test inside a Euro 6 engine



The original rocker arm in a Renault Trucks Euro 6 DTI 5 engine



## Siemens reports success for additively manufactured gas turbine blades

Siemens has completed its first full load engine tests for gas turbine blades produced entirely using Additive Manufacturing technology. Components were tested at 13,000 rpm and temperatures beyond 1,250°C, with the company successfully validating multiple AM turbine blades of conventional blade design at full engine conditions.

The project team used blades manufactured at its recently acquired Materials Solutions facility in Worcester, UK. Materials Solutions specialises in high performance parts for high temperature applications in turbomachinery where accuracy, surface finish and the materials quality is critical to ensure operational performance of the parts in service.

Tests were conducted at the Siemens testing facility in the industrial gas turbine factory in Lincoln, UK. The company also tested a new blade design with a completely revised and improved internal cooling geometry manufactured using AM technology. "This is a breakthrough success for the use of Additive Manufacturing in the power generation field, which is one of the most challenging applications for this technology," stated Willi Meixner, CEO of the Siemens Power and Gas Division.

"Additive Manufacturing is one of our main pillars in our digitalisation strategy. The successful tests were the result of a dedicated international project team with contributions from Siemens engineers in Finspång, Lincoln and Berlin together with experts from Materials Solutions. In just 18 months they completed the entire chain from component design and AM material development to new methods for life simulations and quality controls. With our combined know-how in 3D printing, we will continue to drive the technological development and application in this field," added Meixner.

The blades were installed in a Siemens SGT-400 industrial gas turbine with a capacity of 13 MW. The AM

turbine blades are made out of a powder of high performing polycrystalline nickel superalloy, allowing them to endure high pressure, hot temperatures and the rotational forces of the turbine's high speed operation. At full load each of these turbine blades is travelling at over 1600 km/h, carrying 11 tons, is surrounded by gas at 1250°C and cooled by air at over 400°C. The advanced blade design tested in Lincoln provides improved cooling features that can increase overall efficiency of the Siemens gas turbines.



*The advanced blade design provides improved cooling features*

Siemens extensively uses AM technology for rapid prototyping, but has already introduced serial production solutions for components in the gas turbines' compressor and combustion system. The first AM component for a Siemens heavy-duty gas turbine has been in commercial operation since July 2016.

[www.siemens.com/press/3D-printing](http://www.siemens.com/press/3D-printing) ■■■

## Pushing your imagination

Höganäs' proprietary technology Digital Metal® is making great strides into territories previously ruled by conventional manufacturing technologies. High productivity has brought our 3D metal printing services into large series production.

However, Digital Metal does not only provide a cost-effective way of manufacturing small, complex metal parts not achievable through any other technology. It is also an ideal solution for the production of mass-customised components, or flexible serial volumes.

Every single part in a batch of components can be custom-made, no matter the number. So, yes, it is time so start thinking beyond imagination.

### What's so good about it?

- High productivity
- Excellent surface quality
- High resolution
- Serial production
- Mass-customisation
- Repeatability

**Höganäs** 

Inspire industry to make more with less. [www.hoganas.com/digitalmetal](http://www.hoganas.com/digitalmetal)



*Siemens tested AM turbine blades of conventional and advanced blade design*



## 3D METAL PRINTING

Breaking the barrier of **metal prototyping** and **metal component manufacturing**

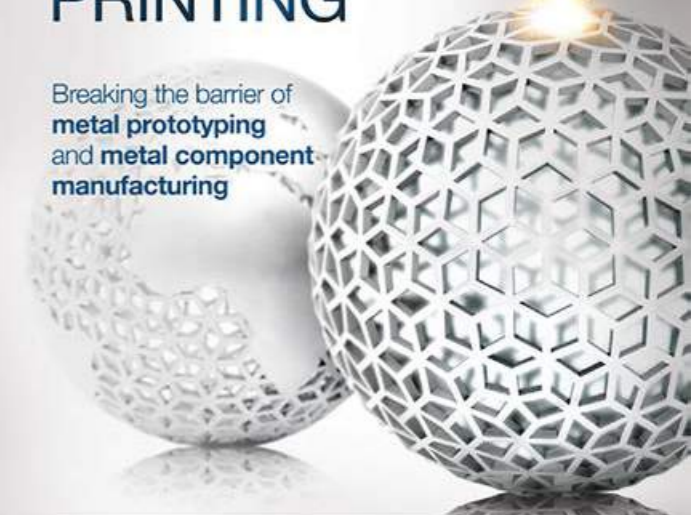

Visit us at [www.amt-mat.com](http://www.amt-mat.com)

For more information, please contact us at [3Dmetalprinting@amt-mat.com](mailto:3Dmetalprinting@amt-mat.com)



Visit us at  
HANNOVER MESSE 2017  
Hall 6, Booth L17



Images courtesy of Robot Bike Co.

## Joining Composites. Refined.

Altair helped Robot Bike Co. combine carbon fiber and 3D printing technologies to develop a fully customizable, lightweight, and high strength mountain bike. We teamed up with HiETA Technologies and Renishaw to make a ground-breaking entry to the market using the very latest design and manufacturing techniques.

We ask you to not just design something. We ask you to DESIGN THE DIFFERENCE™

[altair.com/robotbike](http://altair.com/robotbike)



## Linde and Praxair agree merger to form \$65 billion company

Linde AG and Praxair, Inc. have announced that the companies intend to combine in a merger of equals under a new holding company. The companies have signed a non-binding term sheet and expect to execute a definitive Business Combination Agreement as soon as practicable.

Based on 2015 reported results, the combination of Linde and Praxair would create a company with pro forma revenues of approximately \$30 billion, prior to any divestitures, and a current market value in excess of \$65 billion. Under the proposed terms of the transaction, current Linde and Praxair shareholders would each own approximately 50% of the combined company.

"The strategic combination between Linde and Praxair would leverage the complementary strengths of each across a larger global footprint and create a more resilient portfolio with increased exposure to long-term macro growth trends," stated Steve Angel, Praxair's Chairman and CEO. "We consider this to be a true strategic merger, as it brings together the capabilities, talented people and best-in-class processes of both companies, creating a unique and compelling opportunity for all of our stakeholders."

The combined company would adopt the globally-recognized Linde name and be listed on both the New York Stock Exchange and the Frankfurt Stock Exchange. The new

company will seek inclusion in the S&P 500 and DAX indices.

"Under the Linde brand, we want to combine our companies' business and technology capabilities and form a global industrial gas leader. Beyond the strategic fit, the compelling, value-creating combination would achieve a robust balance sheet and cash flow and generate financial flexibility to invest in our future," stated Professor Dr Aldo Belloni, CEO of Linde.

The combined company would be governed by a single Board of Directors with equal representation from Linde and Praxair. Linde's Supervisory Board Chairman, Professor Dr Wolfgang Reitzle, would become Chairman of the new company's Board. Praxair's Chairman and CEO, Steve Angel, would become CEO and a member of the Board of Directors.

[www.praxair.com](http://www.praxair.com)  
[www.linde.com](http://www.linde.com) ■■■

## Carpenter Technology to acquire assets of Puris LLC for \$35 million

Carpenter Technology Corporation has announced the execution of a definitive asset purchase agreement for the purchase of substantially all of the assets and business of Puris LLC, a producer of titanium powder for Additive Manufacturing and advanced technology applications, for \$35 million. The assets and business to be acquired include Puris' titanium powder operations and business, Additive Manufacturing assets, patents and related intellectual property. The transaction is subject to customary closing conditions and closing is expected to occur during the quarter ended March 31, 2017.

"This acquisition will provide Carpenter with immediate entry into the rapidly expanding titanium powder market and is consistent with our strategic focus on strengthening our leadership position in important growth areas," stated Tony Thene, Carpenter's President & CEO. "Puris brings industry leading technology

and processes for the production of titanium powder, Additive Manufacturing part production capabilities, a talented team, attractive intellectual property and established customer relationships. The strengths of Puris, coupled with Carpenter's reputation as an industry leading producer of premium alloys and our global commercial reach, will allow us to further deliver on the growing needs of our customers," added Thene.

As a result of the transaction, Carpenter will enter the titanium powder market significantly earlier than previously planned and will reduce its planned fiscal year 2017 capital expenditures by approximately \$20 million. Operations will continue at the existing site which is well positioned for future expansion and will operate as a functional unit of Carpenter Powder Products, complementing Carpenter's existing broad portfolio of well-established Powder Metallurgy offerings.

Stephen Peskosky, Vice President of Corporate Development at Carpenter stated, "The addition of titanium powder to Carpenter's existing capabilities is significant due to the current and anticipated demand increases from the Additive Manufacturing industry, which produces mission critical parts supplied to Aerospace and Medical markets, as well as other markets."

Puris is based in Bruceton Mills, West Virginia, and is a leading producer of titanium powder for Additive Manufacturing and other applications. The company is said to utilise world-leading technology and processes for the production of titanium and other pre-alloyed powders of the highest integrity. In addition, the flexibility of Puris' production capacity and process enables fulfilment of both high volume demands, as well as custom lots. Since its founding in 2014, Puris has successfully built leading capabilities, established advanced technology procedures and earned valuable quality approvals and accreditations.

[www.cartech.com](http://www.cartech.com) ■■■

## Oerlikon to invest \$55 million as it expands its US Additive Manufacturing business

Switzerland's Oerlikon has announced the expansion of its global Additive Manufacturing business with a new state of the art R&D and production facility for additively manufactured advanced components in the Charlotte metro area in North Carolina, USA. Oerlikon plans to invest around \$55 million in the facility and expects to create over 100 new jobs.

The Charlotte site will be fully operational in 2018. However, Oerlikon stated that it will begin its AM business activities in Charlotte at an interim facility in early 2017. The investment in a new US facility follows the recent acquisition of citim, a metal AM design and production company located in Germany. The addition of the new site brings

Oerlikon's AM network to four locations globally. The Charlotte site complements citim's sites in Barleben (Magdeburg), Germany, and Atlanta, Georgia, USA, and the new production facility for advanced metal powders for Additive Manufacturing and advanced coatings in Plymouth Township, Michigan, USA.

Oerlikon stated that the new facility will offer US industrial customers a single source for a full suite of integrated services for end-to-end advanced component manufacturing – from R&D, design, applications engineering and series production to post processing. The Charlotte region is home to a rapidly growing number of global industrial, aerospace and automotive firms.

"Innovation is a strategic driver of growth at Oerlikon. We consistently work at strengthening our innovation power and staying at the forefront in developing new technologies in our fields. As we strategically transform to become a powerhouse in surface solutions and advanced materials, we are investing in high growth potential businesses such as Additive Manufacturing," stated Dr Roland Fischer, CEO of the Oerlikon Group.

"Charlotte is an important step in our plans to grow our Additive Manufacturing business and our investment in key technology areas. The investment underlines our intention to become a leading independent global partner in the industrialisation of Additive Manufacturing. I would like to thank our economic development partners in North Carolina and the Charlotte region for their support in our investment," added Fischer.

[www.oerlikon.com](http://www.oerlikon.com) ■■■

## GKN and EOS collaborate to focus on metal AM for automotive market

GKN Powder Metallurgy has announced it is joining forces with EOS to spearhead business-to-business industrial Additive Manufacturing. The two companies agreed on a collaboration, primarily aimed at the automotive sector, that combines their know-how and experience to fully exploit the revolutionary possibilities and potential offered by metal AM.

GKN Powder Metallurgy brings expertise in the transfer of innovative technology from laboratory level to series production, particularly in the automotive sector, capabilities in advanced material and design as well as experience in developing and producing advanced metal powder materials. As a pioneer in the development of AM machines, EOS offers all essential elements for industrial 3D printing.

"Metal AM has huge potential to shape the future of industrial manufacturing and its products, and elevating this to a new level. EOS and GKN will take on this challenge together. We want to ensure that more and more companies recognise and use the potential of this innovative technology. At the same time, we want to considerably expand the areas of application with new materials by testing and ultimately using them in series production," stated Dr Peter Oberparleiter, CEO GKN Powder Metallurgy. Commenting on the announcement, Founder and CEO of EOS, Dr Hans J. Langer, added, "The collaboration between GKN and EOS is another important step towards integrating industrial 3D printing into existing and future production lines and to leverage the benefits of AM technology for series production. With



*Dr Hans J Langer, Founder and CEO of EOS (left) and Dr Peter Oberparleiter, CEO GKN Powder Metallurgy (right)*

GKN we have the right partner who offers a high degree of experience with its global presence and its high-performance production for the automotive industry."

In 2016, GKN Powder Metallurgy and EOS held their first joint 'AM Experience Day' at GKN's Innovation Centre in Radevormwald, Germany. Based on the huge interest the partners are now planning to run a further eight 'AM Experience Days' in Europe and North America in 2017.

[www.gknsintermetals.com](http://www.gknsintermetals.com)

[www.eos.info](http://www.eos.info) ■■■

[www.kymerainternational.com](http://www.kymerainternational.com)

# Lightweight Additive Manufacturing

**eckagranules**  
Metal-Powder-Technologies

**Global Leaders in Aluminium and Copper powders**

**Kymera**  
INTERNATIONAL  
Pioneers in Material Science®

# A REVOLUTION IN METAL AM IS COMING

# 3DDEO

LOW COST, HIGH VOLUME METAL AM MANUFACTURING

[WWW.3DEO.CO](http://WWW.3DEO.CO)

## Markforged introduces new Atomic Diffusion Additive Manufacturing technique

Markforged, based in Cambridge, Massachusetts, USA, has introduced its Atomic Diffusion Additive Manufacturing (ADAM) process which it claims is a breakthrough technology in metal manufacturing. The company, known for its successful development of carbon fibre printing technology introduced in 2014, also announced its Metal X system, the first ADAM 3D printer.

"Until today, the story of metal 3D printing has been million-dollar machines that fill a room," stated CEO Greg Mark. "With the introduction of the Metal X, metal production is easier and more available than ever. Manufacturers and machine shops looking to augment CNC machining

or find alternatives now have an answer."

"This revolution is not just about making metal parts – it's also about making plastic parts from a 3D printed metal mould created in days, instead of months. Our mission is to help companies make better products, and get them to market faster."

The ADAM technique is said to produce robust, accurate parts across a wide range of engineering metals. Parts are printed layer-by-layer using a metal powder contained in a plastic binder. After printing, plastic binders are removed and the part sintered. At launch, the Metal X will print high-end stainless steels such as 17-4 and 303. With a build volume of 250 x 220 x



The Metal X is the first ADAM based system

200 mm the Metal X starts at \$99,500, with first orders being shipped in September 2017.

[www.markforged.com](http://www.markforged.com) ■■■

## Concept Laser, Honeywell and PADT build new Additive Manufacturing Centre

The Polytechnic School at Arizona State University (ASU), Texas, USA, has partnered with Concept Laser, Honeywell Aerospace and Phoenix Analysis and Design Technologies, Inc. (PADT) to build a new Additive Manufacturing research facility, said to be the largest in the Southwest, on the Polytechnic campus. The 15,000 ft<sup>2</sup> centre is home to over \$2 million of polymer and metal AM equipment.

The lab has a Concept Laser M2 cusing and Mlab cusing machine which are dedicated to metal Additive Manufacturing. The Polytechnic School is using the machines for a wide range of research and development activities including materials development and prototyping complex mechanical and energy systems.

"Honeywell is thrilled to be participating in the opening of the new additive manufacturing laboratory at

the Arizona State University Polytechnic campus," stated Don Godfrey, Engineering Fellow at Honeywell. "For many years, we have worked with ASU seniors on their capstone projects with three of these projects this school year being Additive Manufacturing focused. In addition to our own Additive Manufacturing operations, we have provided mentorship to students in the program and assisted in the procurement of one machine for the school's new lab. We look forward to growing our relationships with the university in developing brilliant minds to tackle and overcome industry challenges associated with aviation and Additive Manufacturing."

"Changing the future of metal Additive Manufacturing begins with educated teachers and curious students. The educational leadership that the ASU Polytechnic School provides to the Southwest region

and the industry will certainly be impactful. Concept Laser is proud to be a partner in this initiative," added John Murray, President and CEO of US-based subsidiary Concept Laser Inc.

PADT, Inc is an engineering product and services company that focuses on helping customers who develop physical products by providing Numerical Simulation, Product Development and 3D Printing solutions. Rey Chu, the company's Principal, Manufacturing Technologies, stated, "This partnership is the next and obvious step in the progression of Additive Manufacturing in the Southwest. With Concept Laser's outstanding technology, Honeywell's leadership in applying Additive Manufacturing to practical aerospace needs, PADT's extensive network of customers and industry experience, and ASU's proven ability to educate and work with industry, the effort will establish a strong foundation for the entire regional ecosystem."

[www.conceptlaserinc.com](http://www.conceptlaserinc.com)  
[www.PADTINC.com](http://www.PADTINC.com)  
[www.asu.edu](http://www.asu.edu) ■■■



Plastic gripper for handling of chips packages, built with EOS System for Plastic Additive Manufacturing. (Source: Formrise)  
Metal weight optimized bracket, built with EOS System for Metal Additive Manufacturing. (Source: Airbus, Sogeti)

## Shatter Manufacturing Boundaries with industrial 3D Printing

Adapt your production to the needs of a connected world. Whether rapid prototyping or serial production, EOS systems allow you to manufacture innovative and high-quality parts made of metals or plastics. We offer solutions for all industries.

Visit us at

**AMUG Conference**, Chicago, IL. March 19-23, 2017

**RAPID+TCT**, Pittsburgh, PA. May 08-11, 2017 / Booth 1237

[www.eos.info](http://www.eos.info)



e-Manufacturing Solutions



## Arcam cites major investments and challenging market situation in 2016

Following a strong fourth quarter, Arcam AB, Mölndal, Sweden, has reported that it closed the year with net sales of 648.3 MSEK (\$71.7 million) and an operating profit of -29.8 MSEK (-\$3.3 million). The underlying operating income amounted to 15.0 MSEK (\$1.7 million) after adjustments for non-recurring costs. During the year the company received 48 orders for its EBM machines, compared with the previous year's total of 58. Arcam added that it enters 2017 with an order book for 25 systems.

"The second half of the year was dominated by GE's tender which for us is a strong confirmation that the business that we have built together now becomes a major player in the AM industry. The bidding process had an impact on our operations since management had less time to act in the market. Our EBM customers took

a somewhat cautious position and we see that it takes longer to close new orders," stated Magnus René, Arcam's President and CEO.

### New EBM systems launched

During the year the company launched enhanced versions of the Arcam Q-series EBM systems. The Arcam Q10plus and Arcam Q20plus systems offer up to 25% higher productivity with improved surface finish and precision. Arcam also introduced its Arcam xQam™, an X-ray based function for high precision auto-calibration and improved beam control.

### AP&C expansion

AP&C, Arcam's titanium powder division, added significant capacity by building a new powder manufacturing plant. At the end of 2016 the company had eight reactors in operation at the

existing facility in Montreal, Canada and will reach a capacity of at least 750 tons per year by the end of 2017. The new plant will be built in modules and can be extended to reach a total capacity of over 1,200 tons per year in both production plants.

### Ownership structure

On September 6, 2016, GE made a public offer to acquire all shares of Arcam AB. GE's offer was completed on November 29 and GE currently owns 76.15% of all shares of Arcam.

"In connection with the [GE] offer the fund Elliott acquired over 11% of the shares and thus became the second largest shareholder. With some of the world's largest companies as customers, a strong cash position and, most important, a team of dedicated and driven employees, we are well positioned to take advantage of our opportunities in the fast growing market for Additive Manufacturing," concluded René.

www.arcam.com ■■■

## Metal Additive Manufacturing

Visit us at:  
**RAPID + TCT  
2017**

Booth 2215

citim is a service provider specialized in Additive Manufacturing for prototypes and production parts.

Furthermore, all services are brought together in one place covering the whole production chain: part design, printing process, CNC machining and post processing. citim has its own development capacities for new materials and parameter optimization.

The service bureau is a leading supplier for metal AM components with production facilities in Europe and North America.

Now get the benefit from our experience and our know-how, worldwide and over numerous business segments.

For more information visit our website [www.citim.de/en](http://www.citim.de/en) and [www.citim-am.com](http://www.citim-am.com)

citim GmbH

Steinfeldstrasse 7  
39179 Barleben | Germany  
Phone: +49 (0) 39203-5106-0  
E-mail: [info@citim.de](mailto:info@citim.de)



citim AM, Inc.

1590 N Roberts Rd NW | Suite 113  
Kennesaw | GA 30144 | USA  
Phone: +1 770-575-2899  
E-mail: [info@citim-am.com](mailto:info@citim-am.com)

## Materials

- Aluminium (AlSi7Mg, AlSi10Mg, AlSi9Cu3)
- Aluminium - Scalmalloy®
- Cobalt Chrome (CoCr)
- Copper Alloy (CuNi2SiCr)
- Inconel (IN625, IN718)
- Stainless Steel (316L, 17-4, 1.4859)
- Titanium (TiAl6V4)
- Tool Steel (1.2709)



Can you make  
metal 3D printing  
affordable for all



Well, we already have.



**ORLAS  
CREATOR**

[creator.orlaser.com](http://creator.orlaser.com)

## Submarine manufacturer turns to AM for titanium ballast tank

Sciaky, Inc., Chicago, USA, has used its Electron Beam Additive Manufacturing (EBAM) technology to build a titanium variable ballast tank for International Submarine Engineering (ISE), Ltd., saving a significant amount of time and cost when compared with traditional manufacturing processes.

ISE is said to have approached Sciaky after the closure of its former supplier, an overseas titanium forging facility that produced propellant tanks for the Russian space program. A new titanium variable ballast tank was manufactured for ISE using Sciaky's EBAM process, reducing production time from sixteen weeks to eight weeks, as well as reducing overall costs as compared to retooling with a new forging supplier.

"Sciaky is proud to help ISE cut production time by 50% and reduce costs by 3D printing their titanium

variable ballast tanks with our one-of-a-kind EBAM process," stated Bob Phillips, Vice President of Marketing for Sciaky, Inc. "Our industry-leading EBAM technology is the world's only industrial-scale metal 3D printing solution with approved parts for land, sea, air and space applications."

The titanium variable ballast tank is a sub-system of ISE's Arctic Explorer Autonomous Underwater Vehicle (AUV) class of vehicles. ISE previously built two Arctic Explorers for Natural Resources Canada/Defence Research and Development Canada (DRDC) to map the sea floor underneath the Arctic ice shelf. The Arctic Explorer is the largest of the Explorer AUV class, measuring over seven metres long and weighing over 2000 kilograms.

The unique ballast system enables the AUV to park on the sea floor or hold itself on the underside of the



ice during missions. Rated to 5,000 metres depth, the Arctic Explorer is designed to remain underwater between missions for extended periods of time. A small remotely operated vehicle conducts all servicing and charging after the AUV is attached to a docking head.

The EBAM titanium variable ballast tank has reportedly passed the same vigorous qualification testing as the original forged tank and ISE is said to have plans to manufacture other critical titanium parts using Sciaky's EBAM process.

[www.ise.bc.ca](http://www.ise.bc.ca)  
[www.sciaky.com](http://www.sciaky.com) ■■■

### Introducing New Materials for Binder Jet Printing



Here's how Stainless Steel BLDRmetal™ J-10 compares to AISI 420 (DIN 1.4021)\*

**3X wear resistance**

**3X impact resistance**

**OUTPERFORM**

\*both metals infiltrated with bronze

LEARN MORE ABOUT NANOSTEEL BINDER JET POWDER AT:  
[NANOSTEELCO.COM](http://NANOSTEELCO.COM) | 877.293.6266 (NANO)



## Growing a world with limitless potential

### Introducing GE Additive

At GE, we're passionate about the transformative power of advanced manufacturing. That's why we're committed to leading the additive industry through world-class machines, materials and services.

Together, we can accelerate innovations across industries and help the world work smarter, faster and more efficiently. See how we're expanding the boundaries of what's possible at [geadditive.com](http://geadditive.com).



## GE announces financing options to help stimulate growth in Additive Manufacturing

GE has announced that the group's GE Additive division is to collaborate with GE Capital to sell and finance metal Additive Manufacturing machines. The move will see GE Capital develop a range of customised financial solutions, allowing GE Additive customers the ability to access strategic and flexible financing solutions to acquire Additive Manufacturing technology in countries around the world. The company stated that manufacturing companies will now have more ways to access transformative AM technology, spurring growth in several critical industrial markets including medical, aerospace, automotive and machining.

"Our dual expertise both in manufacturing and in equipment finance, allows us to create competi-

tive financial solutions that support our customers' strategic business goals," stated Trevor Schauenberg, President and CEO of GE Capital Industrial Finance. "Additive Manufacturing is a key contributor to the manufacturing evolution; we're excited to enable its growth."

GE has invested approximately \$1.5 billion in advanced manufacturing and additive technologies, in addition to building a global network of Additive Centres focused on advancing the science. GE also recently announced it has acquired a 75% stake in Concept Laser GmbH and 76% of the shares in Arcam AB – both producers of metal AM machines.

[www.geadditive.com](http://www.geadditive.com)

[www.gecapital.com](http://www.gecapital.com) ■■■

## LPW's US facility achieves aerospace quality standard

LPW Technology has announced that its US operation based in Pittsburgh, Pennsylvania has been awarded the quality management standards AS9120A and ISO 9001:2008.

"LPW's ethos is to provide evidence-based quality assurance for its customers across the globe," stated John D Hunter, General Manager of LPW Technology, Inc. "The award of the USA quality standards complements our UK achievements, where we've already attained ISO 9001:2008, ISO 13485:2012, AS 9100C and AS 9120A."

"Achieving AS 9120A for the procurement and supply of specialist powders for laser and electron beam AM processes assures our customers of product quality," added Hunter.

[www.lpwtechnology.com](http://www.lpwtechnology.com) ■■■

## MIM 3000 Debind and Sinter Equipment For Additive Manufactured / 3D Printed Parts



- Any Binder + Any Process Parameter
- Sizes from 27 - 292 Liters
- Pressures from 10<sup>-6</sup> to 900 mbar
- Vacuum, Ar, N<sub>2</sub>, H<sub>2</sub>
- Removable Center Rail for Large Parts

Toll Work, Processing Support and Turn Key Start up Solutions provided by DSH Technologies, LLC



**Elnik Systems, LLC**  
 107 Commerce Road  
 Cedar Grove, NJ 07009 USA  
 T: +1.973.239.6066  
 F: +1.973.239.3272  
 E: [elnik@elnik.com](mailto:elnik@elnik.com)

# High Pressure Heat Treatment perfects the properties of your 3D printed parts



Photo courtesy of Sintavia, LLC.

### The global leader in high pressure technology

Quintus Technologies specializes in the design, manufacture, installation, and support of high pressure systems for sheet metal forming and densification of advanced materials and critical industrial components.

Headquartered in Västerås, Sweden, and represented in 35 countries worldwide, the company is the world leader in high pressure technology and has delivered more than 1,800 systems to customers across the globe within industries such as aerospace, automotive, energy, and medical implants.

Do you want to know how High Pressure Heat Treatment can help you eliminate the porosity, perfect the material properties and shorten lead time from weeks to hours?

Visit [quintustechnologies.com](http://quintustechnologies.com) for more information!

Visit us at Rapid & TCT, May 8-11, Pittsburgh, Pennsylvania. Booth #841

[quintustechnologies.com](http://quintustechnologies.com)



## €50 million research programme for metal AM initiated by Fives Michelin Additive Solutions

An applied research programme for metal Additive Manufacturing, initiated by the Fives Michelin Additive Solutions joint-venture, has been announced under the acronym SOFIA, SOlutions pour la Fabrication Industrielle Additive métallique (Solutions for Industrial Metal Additive Manufacturing). With a budget of more than €50 million, the programme is funded by the Auvergne-Rhône-Alpes region as well as French investment bank, Bpifrance.

SOFIA's aim is to contribute to the development of metal Additive Manufacturing technology by working with the entire value chain (powders, production equipment and processes). It was stated that the six-year applied

research programme will develop technological 'bricks' which can be used to manufacture robust parts at competitive prices, particularly to meet the requirements of the aviation industry. Work will focus on four key areas:

- Perfecting metal powder ranges
- Improving the productivity of Additive Manufacturing machines by optimising the material / process pairs and developing new energy sources
- Designing new ranges for parts with optimised technical and economic characteristics, with a view towards digital continuity
- More broadly, increasing the knowledge of the HSE (health,

safety and environment) risks linked to metal Additive Manufacturing in order to create a repository.

Industrial partners in the project include Fives Michelin Additive Solutions under its AddUp brand, Aubert & Duval, ESI Group, FusiA, Michelin, Safran, Volum-e, Zodiac Aerospace.

Partners from academic institutions include France's CNRS (Centre National de la Recherche Scientifique) and the research universities of Centrale Supélec, Centrale Nantes, Ecole Polytechnique, ENS Paris-Saclay (ENS Cachan), University Paris Diderot, University of Paris-Sud, Pierre and Marie Curie University – Paris VI.

For further information contact: Claire Mathieu-André at Fives: (claire.mathieu-andre@fivesgroup.com)

www.addupsolutions.com ■■■

## New Zealand's RAM3D opens new metal Additive Manufacturing facility

New Zealand's Rapid Advanced Manufacturing (RAM3D) has announced the opening of a new facility in Tauranga's Tauriko Business Park, with the aim of making metal Additive Manufacturing more accessible to the Australian and New Zealand markets. The company has been collaborating with Renishaw and has already installed several AM250 metal Additive Manufacturing systems at the new site, with plans to install 20 systems by the end of 2020.

RAM3D was spun out of the research organisation Titanium Industry Development Association (TiDA) and is Australasia's largest centre for metal Additive Manufacturing. RAM3D's new facility allows companies from a range of sectors, including aerospace, defence, consumer and industrial, to explore the benefits of the metal AM process.

"The AM market is on the rise in New Zealand and Australia," stated Warwick Downing, Managing Director of RAM3D. "This growth is fuelled by realism, not hype; the enquiries we are getting show a clear understanding of the potential of design for additive manufacturing. This is an encouraging trend. We believe this trend is being driven by industry collaborations that facilitate a better understanding of the technology, such as the one between RAM3D and Renishaw."

The company works with its clients to improve the design of production parts and prototypes. It also uses Additive Manufacturing to make these parts in a more efficient and cost-effective manner. RAM3D stated it is collaborating with businesses as far away as Singapore, with the products manufactured at the Tauranga centre used around the world.



RAM3D's new facility in Tauranga, New Zealand

"RAM3D strongly believes that AM is a competitive production technology with an unprecedented potential for industry," stated Mike Brown, Managing Director of Renishaw Oceania. "The company's unique combination of skills, facilities and experience make it an industry leader in this part of the world. It is a privilege for Renishaw to collaborate with such a key player in the market to grow the region's adoption of AM."

www.rapidman.co.nz  
www.renishaw.com/additive ■■■

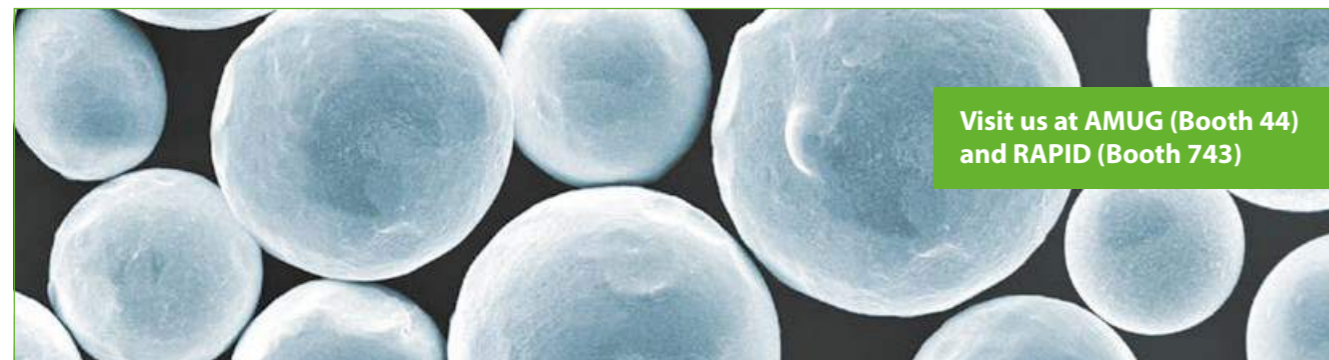

Visit us at AMUG (Booth 44)  
and RAPID (Booth 743)

Technology Metals | Advanced Ceramics

### AMPERSINT® Atomized Metal Powders and Alloys

H.C. Starck offers a wide variety of special gas atomized high-alloyed metal powders, as well as customized solutions for all Additive Manufacturing processes.

- > Extensive product portfolio
- > Constant quality
- > Homogenous particle size distribution
- > Excellent reproducibility
- > Optimized for all AM processes
- > Flexible production quantities

Please contact us to learn more about our unique capabilities for customized powder development both for R&D and large scale production.

Additive.Manufacturing@hcstarck.com  
www.hcstarck.com

H.C. Starck

# ELCAN

High Performance Screening for Metal Additive Powders  
Efficiently Removes Fines From Raw Material to 10 Microns  
Recycle Bed Material with Higher Efficiency  
Machinery Systems & Toll Processing

Contact us today to see how we can  
improve your additive process!  
(914)-381-7500 | sales@elcanindustries.com

elcanindustries.com  
20 Marbledale Road  
Tuckahoe NY 10707 US

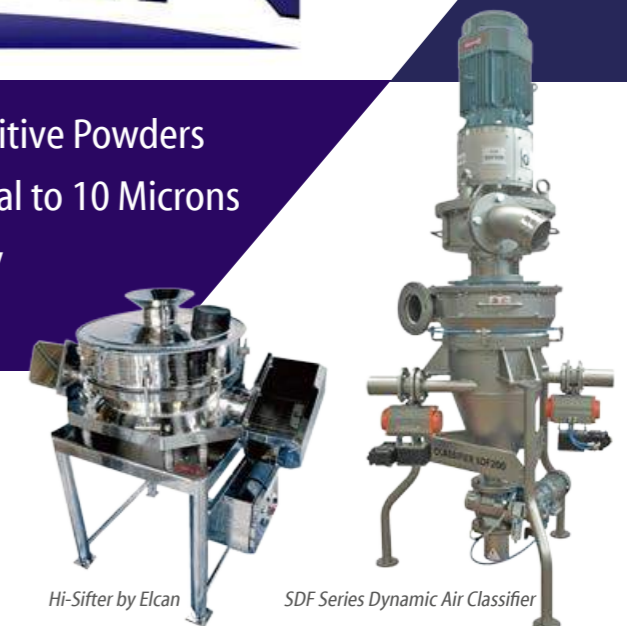

Hi-Sifter by Elcan

SDF Series Dynamic Air Classifier

Visit us at the Rapid Show Booth #1055!

## GKN Powder Metallurgy's digital future in serial metal Additive Manufacturing

GKN Powder Metallurgy has announced further steps in its move towards Industry 4.0 with a new dedicated digital area for metal Additive Manufacturing. At a recent meeting with key customers and partners at its plant in Bonn, Germany, the world's largest producer of precision powder metallurgy products shared plans to start a metal AM digital

enterprise in Q2 2017 using best-in-class workflow, taking the most important aspects of the Industry 4.0 agenda from theory to practice.

Based on intelligent, connected systems, the company stated it will benefit from reduced lead times, enabling stronger customisation of products. On the process side, business partners will be much

more involved in development and production.

GKN is working to drive innovations across the whole metal AM value chain, from production of metal powder materials, AM design and manufacturing services. It will also provide the first fully digitised AM process chain in serial production for automotive, industrial and consumer products. "As an innovation leader in metal AM serial production, we are fully committed to taking a pioneering role in the industry in terms of digitalising our company and our offers. We will actively shape the future and demonstrate that we can do this with the next step we take with our metal AM serial production plant," stated Guido Degen, Senior Vice President Business Development & Advanced Technology.

### Benefitting the complete value chain

It was stated that by concentrating on the implementation of digital and production processes, all work steps along the entire value chain will be substantially leaner and more efficient in the future. For example, this promises a noticeable reduction in development and production times in prototype construction in the automotive area. In addition, digital processes allow for considerable advantages compared to conventional process chain and production methods. GKN Powder Metallurgy added that the plant in Bonn will fulfil the ISO 16949 (automotive), AS 9100 (aerospace) and ISO 13485 (medical devices) certification norms.

### Mix of technology and individual consulting

Individual consulting will continue to play a large role in product development and the optimisation of processes. "The combination of personal contact and technical pioneering spirit makes us successful. This is an indispensable part of our corporate DNA and naturally of our new corporate metal AM strategy," added Degen.

[www.gknsintermetals.com](http://www.gknsintermetals.com) ■■■



## Sintervac® AM debind and sinter vacuum furnaces for Additive Manufactured parts

Over 6,500 production and laboratory furnaces manufactured since 1954



- Metal or graphite hot zones
- Processes all binders for metals or ceramics
- Sizes from 8-1500 liters (0.3-54 cu ft.)
- Pressures from 10<sup>-6</sup> mbar to Atmosphere
- Precision heat treating post processing available
- Vacuum, Ar, N<sub>2</sub> and H<sub>2</sub>
- Max possible temperature 3,500°C (6,332°F)
- Worldwide field service, rebuilds and parts for all makes

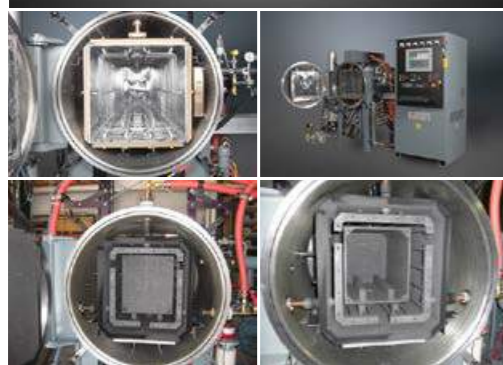

### Sintervac® AM Workhorse™ AM

Centorr Vacuum Industries  
55 Northeastern Blvd  
Nashua, NH 03062  
USA  
Tel: +1 603 595 7233  
Fax: +1 603 595 9220  
Email: [sales@centorr.com](mailto:sales@centorr.com)

[www.centorr.com/am](http://www.centorr.com/am)



VISIT US AT  
rapid + tct  
BOOTH  
740

## On the leading edge of metal powder manufacture



With over 35 years' experience in gas atomisation, Sandvik Osprey offers an extensive range of high quality, spherical metal powders for use in Additive Manufacturing. Our products are used in an increasingly diverse range of applications including automotive, dental, medical, tooling and aerospace.

Our extensive product range includes stainless steels, nickel based superalloys, maraging steel, tool steels, cobalt alloys, low alloy steels and binary alloys.

Using gas atomised powders can enhance your productivity and profitability: contact our technical sales team today for more information.



Sandvik Osprey Limited  
Milland Road Neath SA11 1NJ UK Phone: +44 (0)1639 634121 Fax: +44 (0)1639 630100  
[www.smt.sandvik.com/metalpowder](http://www.smt.sandvik.com/metalpowder) e-mail: [powders.osprey@sandvik.com](mailto:powders.osprey@sandvik.com)

## Established machine shop charts move into metal Additive Manufacturing

Imperial Machine & Tool Co., an established family run engineering business based in Columbia, New Jersey, USA, has a rich and varied history spanning some 73 years. Founded in 1943, the company has developed a reputation for tackling numerous challenging projects and employing the most state of the art equipment available. The company provides engineering and manufacturing services to a wide variety of customers including leading technology companies, research institutions and the US government. Looking to stay at the forefront of new technologies, Imperial installed its first metal AM machine in 2013.

Metal Additive Manufacturing has yet to fully break into mainstream manufacturing operations and, although the market is growing significantly, it is still rare to find metal AM capabilities outside large corporations or advanced research institutions. It's particularly rare to find the capability married with advanced multi-axis CNC machining capabilities such as those found at Imperial.

"In 2012, my son Christian and I were discussing capital equipment needs over lunch one day and the topic turned to metal Additive Manufacturing," stated Chris Joest, President of Imperial Machine & Tool Co. "We had been using polymer based AM for quite some time so I was familiar with the technology, but frankly metal additive wasn't even

on my radar. I had been thinking along the lines of additional 5-axis machining centres or a large horizontal machining centre."

"Christian pointed out some of the very interesting things that were going on in additive at the time and that certainly piqued my interest. Upon further study I got our team together and said, 'We should get out in front of this metal 3D printing technology. It has current benefits for us and our customers and clearly is the wave of the future for manufacturing'."

Imperial bought an SLM 280 HL in 2013 and experienced a very steep initial learning curve both internally and with customers. "I told my team we might lose our shirts for the first couple of years (and we did), but I had no doubt that over time the investment would pay off. In house we had to decide how best to marry the new capability into our operations. With our customers, we found we had to start the conversation at a much different point than a typical machine shop conversation – beginning with what metal AM is really capable of. On the whole though, there was excitement and frankly wonder at what we could now create."

While it took a couple of years, the metal additive department was soon getting busier and busier and in 2015 Imperial purchased a second SLM 280 HL "Twin-Laser" to keep up with their growing additive workload. The company intends to continue investing

in additive and is shopping for new and larger tools and capacities.

"We've really hit our stride in the last couple of years. In particular we've been able to separate ourselves by offering comprehensive hybrid manufacturing services that marry additive and subtractive techniques effectively. Having extensive machining, welding and fabricating experience provides significant advantages since almost all metal additively manufactured items require some level of machining after they are printed. Many additive shops and organisations simply can't do this because they don't have the robust machining background we have. Hybrid manufacturing is what's unlocking the most innovative designs, not just additive on its own," continued Joest.

"We're honoured to be invited to share some of the things we've learned with the folks at RAPID. While we can't share our most interesting items due to confidentiality and IP concerns, we're going to bring some pretty cool examples of hybrid manufactured parts to the show. Once folks see what the possibilities are, they understand why we are laser focused on Additive. It's truly the next generation of manufacturing"

Imperial will be discussing its journey into metal AM during a presentation at Rapid + TCT 2017, May 8-11, Pittsburgh, USA. The company also has an exhibition booth, #2441, where it will display a full array of hybrid manufactured components.

[www.imperialmachine.com](http://www.imperialmachine.com)  
[www.rapid3devent.com](http://www.rapid3devent.com) ■■■

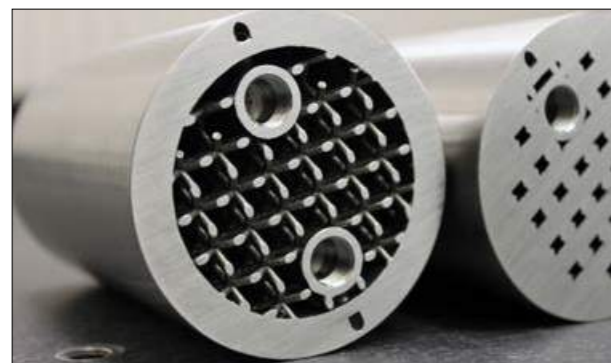

*This Inconel component is additively manufactured then precision machined. The project was a collaboration between Imperial and Penn State's CIMP-3D facility*

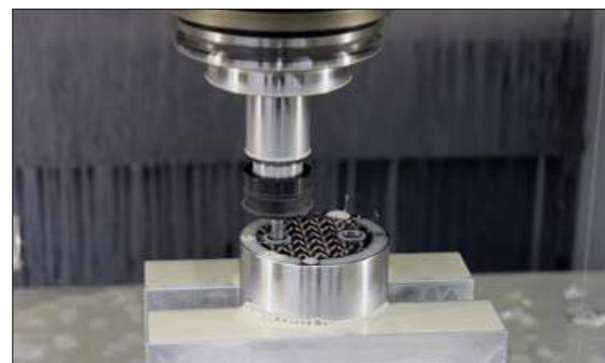

*Precision thread milling of special SAE threads on an additively manufactured Inconel component at Imperial's facility in Columbia, New Jersey, USA*

# US Metal Powders, Inc.

## AMPAL | POUDRES HERMILLON

### Advanced Engineered Aluminum Powders

#### Shaping the Future Together



U.S. Metal Powders, Inc. has been a global leader in the production and distribution of metal powders since 1918. Together with our partners and sister companies, AMPAL and POUDRES HERMILLON, we are helping to shape the future of the metal powder industry.

#### Dedicated Research, Leading Edge Technology, Global Production and Customization

- Nodular and spherical aluminum powders
- Aluminum pre-mixes
- Aluminum alloy powders
- Specialist distributor of carbonyl iron and stainless steel powders

Tel: +1-908-782-5454 (x224)  
Email: [sales@usmetalpouders.com](mailto:sales@usmetalpouders.com)  
[www.usmetalpouders.com](http://www.usmetalpouders.com)



# TEKNA

## HIGH QUALITY SPHERICAL POWDER

# Ti64

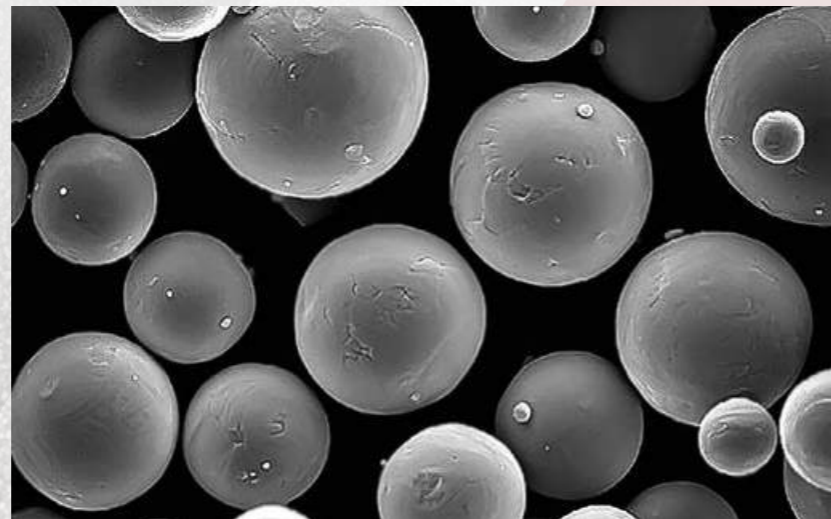

**Our spherical Ti-6Al-4V titanium alloy powder's properties make it the material of choice for Additive Manufacturing**

### Powder Characteristics

- Spherical Shape
- High flowability
- High density
- Extra low oxygen level
- Controlled chemistry

### Powder size cuts available

- 25/5µm
- 45/15µm
- 53/20µm
- 105/45µm
- 250/90µm

Meet with us at  
**Rapid 2017**  
Booth 2452

Contact us for more information  
+1 819 820 2204 • [www.Tekna.com](http://www.Tekna.com)

### SAP widens reach of its industrial Additive Manufacturing programme with UPS

SAP has announced the opening of the early access programme for its Distributed Manufacturing application to new customers as part of its joint collaboration with the global logistics giant, UPS.

The SAP Distributed Manufacturing early access programme intends to provide discrete manufacturers, industrial Additive Manufacturing companies and service providers, materials providers, postal companies and global logistics networks with standard and scalable business processes for digitising, approving, certifying and manufacturing digital parts in an end-to-end digital manu-

facturing process. The programme is part of the SAP Leonardo IoT portfolio.

SAP is currently working with thirty co-innovation companies in the programme and is expanding the initiative to offer more organisations the ability to test and approve 3D printing before the anticipated general availability of the new application from SAP planned for later this year.

Participating companies can explore opportunities to drive innovation by rethinking product design, optimising manufacturing and logistics processes, and creating new business models. They can "right size" their inventory for slow-moving

parts while meeting time-sensitive customer needs, take advantage of opportunities to easily produce unique custom goods and improve production consistency with high-quality, low-cost certified parts.

"This SAP programme is a perfect fit for us," stated Nikolai Zaepernick, Senior Vice President, EOS Central Europe. "It provides an ideal collaboration platform to merge supply and demand for the industrial 3D printing technology we offer. As a leader in this field, EOS contributes a wealth of deep and long-standing technology experience. The platform, on the other hand, enables us to integrate our technology into existing supply chains and production environments on the way to becoming an established way of manufacturing."

[discover.sap.com](http://discover.sap.com)  
[www.sap.com](http://www.sap.com) ■■■

### TWI and Lloyd's Register launch two new projects to advance take up of Additive Manufacturing

The UK's TWI and Lloyd's Register (LR) have announced that they are calling for partners to join two new collaborative projects focused on specific challenges facing the Additive Manufacturing industrial sector. The projects, 'Achieving Regulatory and Code Compliance for Additive Manufacturing' and 'Joining of Metallic Additively Manufactured Products and Materials' aim to explore further challenges uncovered following LR and TWI's first joint industry project, 'Certification of Laser Powder Additive Manufactured Components for Industrial Adoption in the Energy and Offshore Sectors'.

What remains unexplored is the link between Additive Manufacturing and compliance with standards and regulations that are often used in safety-critical pieces of equipment, such as the American Petroleum Institute code (API), the American Society of Mechanical Engineer's (ASME) Boiler and Pressure Vessel Code, and Europe's Pressure Equipment Directive (PED).

The first project will investigate the routes to regulatory compliance of parts selected by project sponsors and will produce data and assessment criteria for the introduction and acceptance of parts through third-party inspection. This will give them a head start on their competition by receiving technical services and support covering design and manufacturing through to testing and inspection.

The second project will concentrate on filling in the real-world gaps (such as controls, data, testing, inspection) to enable project sponsors to design, fabricate and put into service structures that are comprised of conventionally made parts welded with AM parts. Project sponsors will gain the confidence to put parts into service in real-world, challenging operating environments and conditions, which is said to be a significant step forward for industries such as energy, marine and offshore.

[www.twi-global.com](http://www.twi-global.com)  
[www.lr.org](http://www.lr.org) ■■■

### Sigma Labs announces Pratt & Whitney contract

Sigma Labs, Inc., Santa Fe, New Mexico, USA, has announced the signing of a commercial agreement with Pratt & Whitney, a unit of United Technologies Corp, for its PrintRite3D® software along with participation in the company's Early Adopter Program. Established in 2016, Sigma Labs' Early Adopter Program has served to accelerate use of the company's PrintRite3D® quality assurance applications for Additive Manufacturing. Participants include Siemens, Spartacus3D, Woodward, Additive Industries and now Pratt & Whitney.

"I'm very pleased to announce that Pratt & Whitney is joining our Early Adopter Program," stated Mark Cola, President and CEO of Sigma Labs. "Signing high quality, well known customers – coming on the heels of our contract with Siemens just a few weeks ago – clearly demonstrates a growing market for our PrintRite3D® quality assurance software and strong brand recognition for our products." [www.sigmalabsinc.com](http://www.sigmalabsinc.com) ■■■



# Renishaw Solutions Centres... lowering the barriers to Additive Manufacturing



See us at:  
**AMUG**  
 Diamond Suite D1  
**RAPID + TCT 2017**  
 Stand 1629



## Renishaw Solutions Centres - your pathway to innovative AM products

Renishaw Solutions Centres provide a secure development environment in which you can build your knowledge and confidence using metal AM technology.

Equipped with the latest metal AM, machining and metrology systems staffed with knowledgeable engineers, a Solutions Centre offers you a fast and accessible way to rapidly deploy this exciting technology in your business.

Renishaw will support you throughout your investigation and business case development process, helping you to optimise your design, build your confidence in the process, and gain the evidence you need to make investment decisions.

For more information visit [www.renishaw.com/solutionscentres](http://www.renishaw.com/solutionscentres)

Renishaw plc Brooms Road, Stone Business Park, Stone, Staffordshire, ST15 0SH, United Kingdom  
 T +44 (0)1785 285000 F +44 (0)1785 285001 E [additive@renishaw.com](mailto:additive@renishaw.com)  
[www.renishaw.com](http://www.renishaw.com)



## Sciaky to deliver industrial-scale metal AM system to Airbus

Sciaky, Inc., a subsidiary of Phillips Service Industries, Inc. (PSI) based in Chicago, Illinois, USA, has announced that Airbus is to take delivery of one of its Electron Beam Additive Manufacturing (EBAM™) 110 Systems. The aircraft manufacturer will utilise Sciaky's industrial-scale metal 3D printing system to produce large structural parts made of titanium.

Sciaky's EBAM process combines computer-aided design, Additive Manufacturing processing principles and an electron beam heat source. Starting with a 3D model from a CAD program, Sciaky's fully-articulated, moving electron beam gun deposits metal via wire feedstock, layer by layer, until the part reaches near-net shape. From there, the near-net shape part requires heat treatment and post-production machining. In the end, there is minimal material

waste. In addition, the EBAM™ process can be used in any phase of the product life cycle, from rapid prototypes and production parts to repair and remanufacturing applications.

"Sciaky is very proud to partner with a world-class innovator like Airbus," stated Bob Phillips, Vice President of Marketing for Sciaky, Inc. "We all know that metal 3D printing technology is going to revolutionise manufacturing in the aerospace industry and Sciaky is committed to being at the forefront of this movement."

Sciaky's lineup of EBAM systems can produce parts ranging from 203 mm (8 inches) to 5.79 m (19 feet) in length. The machine can process a wide variety of metals and refractory alloys, such as titanium, tantalum, niobium, tungsten,



This photo highlights two different stages of an Airbus rear upper spar that was 3D printed in titanium with Sciaky's EBAM process. The image on the left shows the part in an early preform stage. The image on the right shows the finished part

Inconel and stainless steels. Sciaky's EBAM 110 has a work envelope of 70" (1778 mm) x 47" (1194 mm) x 63" (1600 mm).

[www.sciaky.com](http://www.sciaky.com)



[cartech.com/powderproducts](http://cartech.com/powderproducts)



## CarTech® Micro-Melt® Powders for Additive Manufacturing

- Clean, spherical, gas atomized powders
- Consistent chemistries and particle sizes
- Uniform products and production flow rates

Carpenter Powder Products is one of the largest global producers of prealloyed, gas atomized, spherical metal powders and leads the way as a supplier for Additive Manufacturing, Metal Injection Molding, Surface Enhancement, and Near Net Shapes/Hot Isostatic Pressing processes.

**Request a quote today.**

**US 1-800-992-6825 Europe +46-16-150100 Asia +65-6738-2401**



© 2016 CRS Holdings, Inc. All rights reserved.





### How safe is your AM operation?

Materials. Equipment. Facilities. Staff.

Take a proactive approach to evaluating and managing the safety of your AM investment with the recognized leader in safety.

### UL AM Facility Safety Services

Visit UL at: AMUG, Booth 33 | RAPID, Booth 940



UL.COM/AM  
ADDITIVEMANUFACTURING@UL.COM  
@ULAdditiveMfg

UL and the UL logo are trademarks of UL LLC © 2017

## Concept Laser and its founder receive multiple awards

Concept Laser, Lichtenfels, Germany, has announced that both the company and its President & CEO Frank Herzog have been presented with numerous prizes and awards. As well as winning the 'International Additive Manufacturing Award 2016', Concept Laser and Herzog received five further awards. "Our drive to improve the quality and speed in Additive Manufacturing has helped to establish 3D metal printing as a manufacturing technology and even make it of interest for industrial series production," stated Herzog. "We see the rapid development of recent years and the awards that have come with this as the motivation to continue to advance 3D metal printing and develop it at the very highest level."

### Herzog awarded best pioneer and best CEO

In October 2016, Herzog was honoured by the *European Business* magazine (UK) as the "Best Pioneer in the Manufacturing and 3D Printing Industry 2016." In December 2016, for the second time in a row, Herzog was also awarded "Best CEO in the Additive Manufacturing Industry." This award has been presented for more than eight years in different categories by the *European CEO* magazine in London, UK.

### Focus "Growth Champions 2017"

Concept Laser's successes as a business are also reflected directly in the company's growth in sales. For the second year in a row, Germany's *Focus* magazine voted the developer and machine manufacturer one of the *Focus* "Growth Champions" with its outstanding sales growth. Within the space of three years, sales at Concept Laser rose from €17.7 million to €67.3 million.

### Bavarian Innovation Award 2016

For the third time, the Bavarian State Ministry of the Economy and Media, Energy and Technology, the Bavarian Chamber of Commerce and Industry and the Consortium of Bavarian Chambers of Crafts presented the Bavarian Innovation Award in the Hall of Honour of the German Museum in Munich. The Bavarian State Government presents the award to recognise companies that have the courage and persistence to try new things and develop innovative ideas until they become economically viable. Concept Laser won the coveted award with its 'QM Meltpool 3D' quality assurance module and with the application motto "X-raying without X-rays."

### Materialica Design + Technology Award 2016

Concept Laser and its project partners were also able to win people over with applications at the Materialica trade show in Munich. Together with the companies EDAG Engineering, Laser Zentrum Nord and the BLM Group, Concept Laser received the "Materialica Design + Technology Award 2016."

www.concept-laser.com ■■■

## Large scale lattice structure for complex satellite component

Adimant, a Copenhagen based engineering company providing software and design services for the industrial Additive Manufacturing sector, has reported that it recently worked with Thales Alenia Space in the development of a large scale satellite component.

Thales Alenia Space, Europe's largest satellite manufacturer, approached Adimant regarding design software issues with a particularly complex satellite part. The company wanted to manufacture the component in metal, but the design they had come up with was too complicated to be created as a CAD file that could be transferred to the AM machine.

Adimant's experience and in-house software allowed the company to



The part is said to be among the largest metal lattice structures manufactured to-date with a post machined weight of 1.7 kg and bounding box of 134 x 28 x 500 mm

solve these issues. "Due to the different competences and tools we have in our company, we are capable of handling designs that would make other software give up," stated Erik Andreassen, co-founder of Adimant.

"Our main competence is that we can make a design which exploits the full design freedom of AM, both when it comes to topology optimisation and lattice structures,"

added Andreassen. Both he and Anders Clausen, also a co-founder of the company, have PhDs in topology optimisation. The third co-founder, Klaus Loft Højbjerg, has in-depth knowledge on metal AM thanks to a PhD in experimental physics and many years of practical experience with metal AM machines from the Danish Technological Institute.

www.adimant.com ■■■

### Optimized Metal Powder for Additive Manufacturing

aluminum

cobalt

nickel

stainless steel

titanium

tool steel

sales@additivemetalalloys.com

www.additivemetalalloys.com

## Future manufacturing hub for advanced powder processes launched

MAPP, the EPSRC Future Manufacturing Hub in Manufacture using Advanced Powder Processes, is a £20m research hub led by the University of Sheffield, UK. The hub brings together expertise from the Universities of Sheffield, Leeds, Manchester, Oxford and Imperial College London, together with 17 industry partners and the UK's High Value Manufacturing Catapult. The aim of MAPP is to realise the potential of advanced powder processes to provide low energy, low cost and low waste high value manufacturing routes and products to secure UK manufacturing productivity and growth.

The launch event on January 31st in Sheffield, UK, was attended by 150 delegates from across industry, universities, Catapult centres and sponsors. MAPP Director and RAEng Chair Professor Iain Todd, gave an overview of MAPP's vision and how MAPP aims to address the challenges and opportunities surrounding advanced powder processes through an ambitious interdisciplinary research programme.

"It's an exciting time for powder based processes with new opportunities opening up rapidly in a range of key sectors including aerospace, energy, automotive and healthcare. However, there are still some fundamental scientific issues to be addressed before these technologies can be adopted more widely," stated Todd. "MAPP brings together leading UK researchers, industry and the High Value Manufacturing Catapult to achieve right first time manufacturing for advanced powder processes and develop the next generation of manufacturing technologies. The EPSRC Future Manufacturing Hubs are key element in our approach to tackling the UK's productivity gap and solving some of the longer term challenges faced by the UK's manufacturing industry."

### Leading edge research

Presentations from MAPP's academic partners highlighted how leading edge research is being applied to provide new insights on advanced powder processes and how this new understanding is leading to improved outcomes for UK manufacturing. Professor Peter Lee, from the University of Manchester and the Research Complex at Harwell, spoke about how experiments at the UK's Diamond Light Source are providing new information on the fundamental physics and chemistry of technologies such as Additive Manufacturing. Professor Andrew Bayly, from the University of Leeds, discussed how physical models can give a better understanding of the dynamic behaviour of powders in processes and some of the challenges associated with powder processing.

### Challenges to overcome

Presentations from MAPP's industry partners outlined the opportunities for advanced powder processes, some of

the challenges which need to be overcome and how the research in MAPP, together with aligned programmes funded by industry and UK Government, are overcoming the challenges and delivering benefit for UK productivity and growth. Dr Alison Wagland, Technology Manager at Johnson Matthey, spoke about the use of powders in the production of catalysts for emission control and batteries for energy storage. Dr Rob Sharman, Global Head of Additive Manufacturing at GKN Aerospace, highlighted the opportunities for metal Additive Manufacturing in aerospace and the need to design new materials and powders which were tailored specifically for these new processes. Dr Phil Carroll, Chief Executive Officer at LPW Technology, spoke about the need to understand manufacturing from the perspective of the powder and the need for quality, traceability and consistency of powder materials.

"We've developed a strong vision and plan for MAPP together with our industry, academic and Catapult partners. Today has given us the opportunity to share our vision and plans for MAPP with a wider network so we can start to develop new opportunities for collaboration. The breadth of sectors attending and the feedback we've received demonstrates the appetite and need for MAPP," stated Dr Richard France, Senior Business Development Manager at MAPP.

[www.mapp.ac.uk](http://www.mapp.ac.uk) ■■■

# Advanced CAD for advanced manufacturing.

## nTopology Element



[www.ntopology.com](http://www.ntopology.com)

## COMPLEX PARTS WANTED

+ Metal Laser Melting at toolcraft

**TOOLCRAFT – YOUR PARTNER FOR TOTAL SOLUTIONS IN METAL LASER MELTING**

- ++ Proven in high-end markets such as aerospace and motor sports. ++ For even the most complex geometries.
- ++ From super alloys of all kinds, including high-strength Scalmalloy®. ++ No tooling, time saving and energy efficient. ++ Now also with multi-laser equipment for enhanced productivity.

+ More details and brochure: [www.toolcraft.de/en/metal-laser-melting](http://www.toolcraft.de/en/metal-laser-melting)

## Sintavia develops process for additively manufacturing F357 aluminium

Sintavia, LLC, based in Florida, USA, has announced that it has developed full end-to-end parameters for producing additively manufactured parts in F357 aluminium, as well as other Al-Si alloys, for use in precision manufacturing. Sintavia's proprietary process for printing F357 aluminium powder is said to have been developed specifically to address aerospace and automotive industry needs for components with low density, good processability and heat conductivity.

Though most aluminium alloy parts are manufactured using traditional casting practices, Sintavia is looking to attract industries wanting to expand beyond traditional manufacturing in foundry-grade aluminium alloys. "We are seeing an increased demand for additively manufactured Al-Si parts from both the aerospace and automotive industries," stated

Doug Hedges, Sintavia's President and COO. "With Sintavia's comprehensive manufacturing capabilities, we have developed processes to make F357 aluminium specimens and quickly test them to demonstrate they meet or exceed these industries' strict validation parameters."

Sintavia's exclusive processes are designed to meet critical engineering requirements at every step. By establishing a procedure that not only includes pre-build material analysis but also post-production heat treatment and stress relief, the company claims it is able to produce AM components proven to exceed original design strength by up to 125% at net densities of near 100%. Through the performance of strength validation at ambient, elevated, and subzero temperatures, Sintavia is capable of part validation



Sintavia is a leading independent AM specialist

in all critical environments. With an increasing demand from OEMs for reduced cycle times and improved quality from their manufacturing supply chains, Sintavia states that it is leveraging the speed benefits of AM while offering elite powder analysis, post-processing and mechanical testing on-site.

www.sintavia.com ■■■



## Smit Röntgen offers 3D printed pure tungsten parts for industrial applications

Via Powder Bed Laser Melting we are able to seamlessly accommodate to individual customer needs for both existing and new products. With our in-house technical know-how we support you in optimizing your product design for additive manufacturing. Our 8 year exclusive focus on pure tungsten 3D printing ensures superb accuracy, reliability, product flexibility and quality.

We strive to create added value for the Metal Additive Manufacturing industry by remaining highly focused on innovative product and process development.

Powder Bed Laser Melting offers great freedom of design and facilitates geometric complexity and flexibility. Therefore part variations are endless.

You can contact us directly via email or telephone: [smitroentgen@philips.com](mailto:smitroentgen@philips.com) / + 31 40 27 62 707  
For more information, please visit us at: [www.smitroentgen.com](http://www.smitroentgen.com)

A few examples are:

- Radiation shielding / collimation solutions
- Beam shaping
- Thermal applications
- Balance weights
- Non-magnetic parts and many more...

Smit Röntgen is the first EOS GmbH service provider for pure tungsten parts.



## Renishaw increases Land Rover BAR's performance

Renishaw plc, headquartered in Wotton-under-Edge, Gloucestershire, UK, is helping to incorporate Additive Manufacturing into daily use at the Land Rover BAR America's Cup project team's Technical Innovation Group (TIG). The team has its own, fully equipped traditional machine shop and has an extensive composites team. Between them, these facilities can make almost anything, but if the final part can be additively manufactured then that's the option that will be used.

"The potential of Additive Manufacturing in terms of saving weight and improving efficiency is tremendous," stated Land Rover BAR's Chief Technology Officer, Andy Cloughton. "For example, we took a long hard look at our hydraulics system. Before 3D printing came

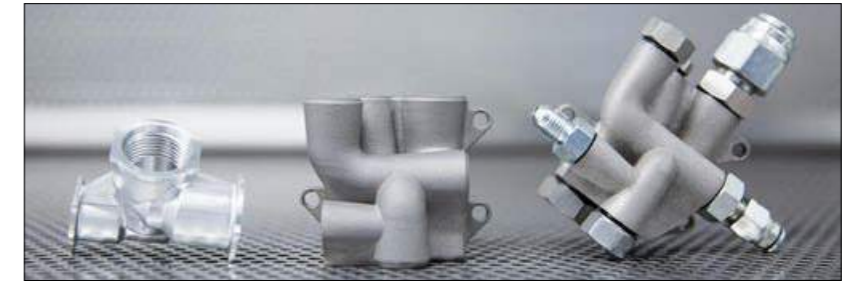

Renishaw has manufactured several parts for hydraulic systems

along all the parts in this system would have been manufactured by taking metal away from a solid block. Hydraulic fluid doesn't take kindly to going around hard corners for instance, and there is a loss of power when it has to do so. With traditional techniques this might be the only way you can manufacture the part, but with Additive Manufacturing you can build it with smooth rounded corners that significantly improves efficiency in the fluid transfers involved."

Renishaw has manufactured several parts for the hydraulic system, resulting in a weight reduction in the new manifold design of 60%, with an

increase in performance efficiency of over 20%.

David Ewing, Product Marketing Engineer at Renishaw, stated, "Our involvement with Land Rover BAR is also helping to raise the bar in AM. It's a complex manufacturing option and there are considerations both in component design and process expertise. The best applications are ones which use the minimum amount of material to achieve the design requirements, offer a functional benefit in service and have been designed with the manufacturing method in mind."

www.renishaw.com/additive ■■■

## Specialized in AM Metal Materials

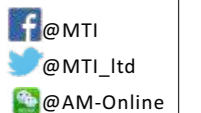

### Gas Atomised Metal Powders

- Cobalt-Chrome Alloys
- Titanium & Titanium Alloys
- Stainless & Tool Steels
- Nickel-based Alloys
- Customized Alloys

### Various Particle Size Distribution for

- SLM
- EBM
- DED



Since MTI foundation, we devote our enthusiasm to Metal Additive Manufacturing community.

Visit us at:



Shanghai, China  
8-10 Mar. 2017  
Booth F64



Pittsburgh, USA  
8-11 May 2017  
Booth 1251



Frankfurt, Germany  
14-17 Nov. 2017

- Tel : +86-(0)20-31040619
- Email : [info@mt-innov.com](mailto:info@mt-innov.com)
- URL : [www.mt-innov.com](http://www.mt-innov.com)

## US Naval Research Laboratory installs Additive Manufacturing machine to enhance R&D

The US Naval Research Laboratory (NRL) has installed its first laser powder-bed metal Additive Manufacturing machine at its base in southwest Washington, DC. NRL will be using Concept Laser's M2 cusing machine to manufacture stainless steel components. Along with the machine, they will be using QM Meltpool 3D to monitor the quality of their metal applications, inspecting the part under construction.

The NRL is the US Navy's full-spectrum corporate laboratory, conducting a broad-based programme of scientific research and development for maritime application related to oceanic, atmospheric and space sciences.

"We require a wide range of Additive Manufacturing (AM) capabilities, ranging from quality monitoring to process parameter development, and need an architecture conducive to that research and development effort," stated Dr Charles Rohde, NRL Acoustics Division.

"It is very exciting that the US Naval Research Laboratory is bolstering their focus on metal Additive Manufacturing. There are so many advantages of 3D metal printing that our defence strategy could benefit from, including reduced lead time, less material waste and printing complex geometries with no required assembly. NRL has a history of over 90 years of innovation in naval power and we



The NRL has installed a Concept Laser M2 cusing machine at its facility in Washington, DC

look forward to hear how they will use 3D metal printing to break boundaries," stated John Murray, President and CEO of Concept Laser Inc. [www.nrl.navy.mil](http://www.nrl.navy.mil) [www.concept-laser.de](http://www.concept-laser.de)



# A GLOBAL LEADER IN METAL AM

Sintavia is the global leader for **Independent Metal AM** for precision industries, including Aerospace & Defense, Oil & Natural Gas, Automotive, and Ground Power Generation.

By leveraging Design for Additive Manufacturing while offering elite powder analysis, post-processing, and mechanical testing on-site, Sintavia offers unprecedented manufacturing services to these important industries.

[WWW.SINTAVIA.COM](http://WWW.SINTAVIA.COM)

- High Speed 3D Printing  
SLM | Concept | Arcam | EOS
- Metallurgical Services
- Powder Analysis
- Metrology & Design
- CT Scanning
- Mechanical Testing
- HIP Services

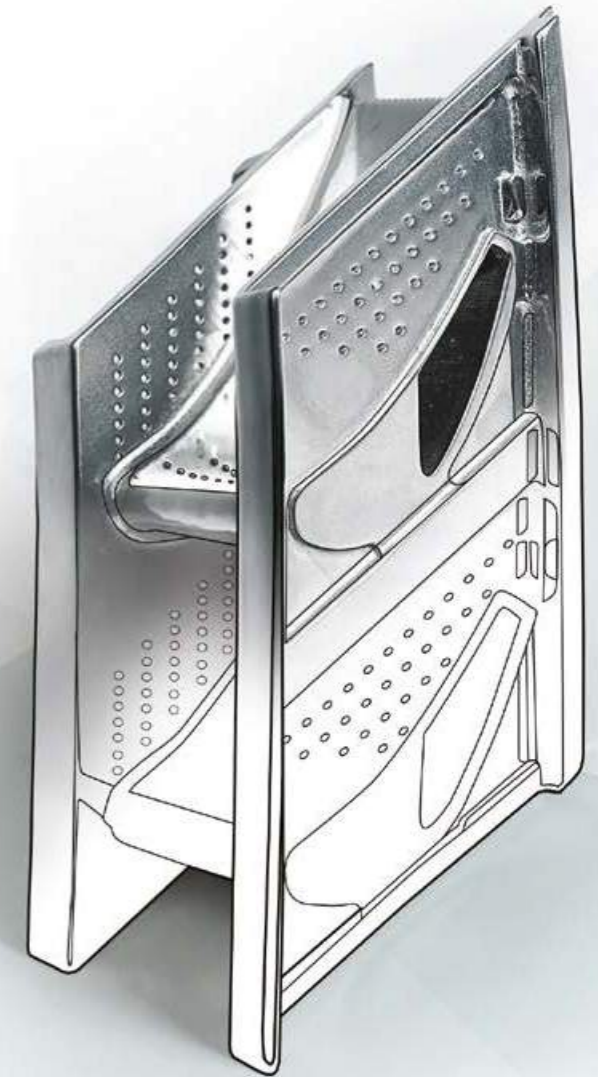

**AS9100** CERTIFIED  
OASIS REGISTERED

**ISO9001** CERTIFIED  
ISO17025 | ANAB ACCREDITED  
ITAR REGISTERED



# KITTYHAWK

P R O D U C T S

# HIP FOR AM

**A world leading provider of HIP services for the AM industry**

Nadcap ISA ANAB

ISO 9001 / AS9100 / FFL

**Kittyhawk Products**  
11651 Monarch Street  
Garden Grove, CA 92841, USA  
Toll Free: 1-800-Kittyhawk + 1 714 895 5024

[www.kittyhawkinc.com](http://www.kittyhawkinc.com)



VACUUM FURNACES DESIGNED FOR HEAT TREATMENT POST ADDITIVE MANUFACTURING

**STRESS RELIEVING, SOLUTION TREATMENT & AGEING of ALLOYS PRONE TO OXIDATION**

Nickel, Titanium, Cobalt-Chrome-Molybdenum, Tungsten



**VACUUM & CONTROLLED ATMOSPHERE TREATMENTS for MATERIALS PRODUCED BY 3D PRINTING**

- Specifically tailored to alloys prone to oxidation,
- Perfect homogeneity thanks to our resistor's patented design,
- Clean treatment: molybdenum heating core and metal insulation,
- Atmosphere control during treatment (optional),
- Productivity increased thanks to an accelerated neutral gas cooling.

Contact : +33 4 76 49 65 60  
info@ecmtech.fr

AMS 2750  
AMS 2769



WWW.ECM-FURNACES.COM

**Inert to debut new powder handling glove box**

Inert, a leading manufacturer of hermetic enclosures and related systems based in Amesbury, Massachusetts, USA, has announced it will debut its new standard glove box enclosure for powder handling from its booth at this year's Rapid + TCT. Designed for the unique requirements of Additive Manufacturing materials, Inert's new powder handling system offers a safe and efficient way to work with, package and store metal powders.

The company stated that it collaborated with several key AM/3D printing companies in 2015 and 2016. "We've taken the solutions Inert engineered for our customers in Additive Manufacturing and combined them into a new, standard glove box model," stated Inert President, Daniel Clay.

"Companies working with metal powders like titanium understand that an inert environment is essential for structurally solid printed results. Our new glove box system has several additional features that make it the ideal solution to the problems these companies face with powder handling and storage," added Clay.

The new powder handling glove box is equipped with a rotating tilt table, ultrasonic vibration, argon gun for de-powdering, unidirectional flow to funnel powders to a collection well and powder storage kegs. The debut of this new system will be coupled with Inert's Argon-2, a closed loop gas management system that provides a continuous recirculation, purification and analysis of the argon environment inside the hermetically sealed glove box. The Argon-2 is one model in a suite of gas management systems offered by Inert to provide safe working conditions for oxygen and water sensitive applications.

Rapid + TCT takes place May 9-11 at The David L. Lawrence Convention Center in Pittsburgh, Pennsylvania, USA. Inert can be found on booth 1147.

www.rapid3devent.com  
www.inerttechnology.com ■■■

**New Additive Manufacturing product area within Sandvik**

Sandvik has announced that it has formed a new product area called Additive Manufacturing within its Sandvik Machining Solutions business area. The foundation for the new product area is the company's Additive Manufacturing centre in Sandviken, Sweden, formally part of R&D at the Sandvik Coromant division.

The company stated that, with this change, Additive Manufacturing within Sandvik is moving from mainly internal use into an external business for metal Additive Manufacturing. The new business will have full profit and loss responsibility and will take a position on the market by organically growing as well as through acquisitions.

www.sandvik.com ■■■



**Additive Manufacturing**  
Metal Powders and Advanced Component Production

From atomization to assembly, Oerlikon provides independent and integrated AM solutions at any industrial level.

We help you reduce product development times and production costs, shorten your supply chain and increase the reliability, performance and sustainability profile of your manufactured products. We partner with you across the entire additive manufacturing value chain.



We can solve your AM challenges. Let's talk.  
www.oerlikon.com/am





Real-time Online Quotes  
Quick Turnaround  
High-Quality Parts

## Experts in: Metal Additive Manufacturing

Design • Rapid Prototyping • Production • Inspection • Post Processing

### Serving Industries Where Precision and Performance Are Critical

Linear AMS delivers expertise in metal AM design and manufacturing. With the proper design, material selection and machine settings, precision parts can be created with high accuracy, detailed resolution and excellent mechanical properties offering improved performance and reliability. Linear AMS produces end-to-end product solutions for real-world applications.

#### Extensive Metal AM Capabilities - From Prototyping to Rate Production

- More than 20 state-of-the-art Direct Metal Laser Melting (DMLM) machines. (i.e. EOS, SLM and Renishaw)
- Single & multi laser systems
- 200, 400 and 1,000 watt lasers
- A variety of standard platform sizes
- Inert argon or nitrogen build environments

#### Metal AM Materials

Aluminum (AlSi10Mg) • Cobalt Chrome (MP1) • Copper (CU-169)  
Hastelloy® X-alloy • Inconel® (625 & 718) • Maraging Steel (MS1)  
NickelAlloy (HX) Stainless Steel (15-5, 17-4, 316L) Titanium (Ti64/Ti64ELI)  
Under Development: Aluminum and Tooling Steel

AEROSPACE • DEFENSE • SPACE • ENERGY • OIL & GAS  
MEDICAL • EMERGING MARKETS  
ISO9001 • AS9100 • ISO/TS16949 • ISO 13485



734.422.6060 | sales@linearams.com | www.linearams.com

### EOS and IESE Business School collaborate to showcase the future of manufacturing

Additive Manufacturing systems maker EOS GmbH, headquartered in Krailling, Germany, and the University of Navarra's IESE Business School with campuses in Barcelona, Madrid, Munich, New York and São Paulo, have announced they are working together to prepare decision makers for Industry 4.0. The core of the collaboration is said to be an Executive Education Programme on Industry 4.0: The Future of Manufacturing. It was stated that IESE and EOS will combine their expertise in the fields of management knowledge and technology know-how, introducing executives to new business models and opportunities focusing on the future of manufacturing.

A three-day edition of the programme is scheduled to take place May 3-5, 2017, in Barcelona, Spain and July 11-13, 2017, in Munich, Germany. It will provide decision-makers with insights into key elements of this transformation process, including technologies such as the connected factory, smart robots and Additive Manufacturing.

"The industry is facing the next big step of development and Additive Manufacturing is playing a key role: the focus is on the integration of Additive Manufacturing into existing and future production environments, which requires optimisation of both part and data flow in serial production," stated Dr. Adrian Keppler, Chief Marketing Officer at EOS.

During the programme EOS will provide first-hand experience of customers who have already integrated industrial Additive Manufacturing into their manufacturing process. It will show how companies can benefit from using this technology in terms of productivity and cost savings.

"In an environment shaped by rapid technology and process change, remaining competitive requires informed, innovative and future-focused leaders. The Industry 4.0 Executive Education Program takes a dynamic, interactive approach to developing participant skills through interactive discussions, lectures and workshops, and direct engagement with manufacturing businesses already on the transitional journey to Industry 4.0. With EOS as the global technology leader for industrial 3D printing, we have the perfect partner to conduct this executive education program," stated Prof. Dr. Marc Sachon, Production, Technology & Operations Management Professor, IESE Business School.

"Together with IESE, we can prepare the management in manufacturing companies for the new challenges due to the digital transformation and communicate the advantages of new production models such as additive manufacturing in a way that they can quickly generate a genuine value-add for their own business," added Keppler.  
www.iese.edu/industry4  
www.eos.info ■■■



Cambridge Sensotec Ltd  
W: www.cambridge-sensotec.co.uk  
E: info@cambridge-sensotec.co.uk  
T: +44 (0)1480 462142

How fast, accurate and reliable is your inert additive manufacturing build chamber?

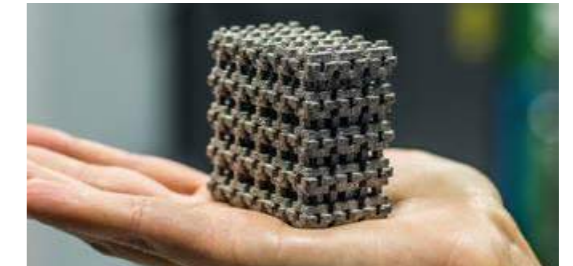

Oxygen analysis used within the metal powder additive manufacturing (AM) process enhances both quality control and ensures safety.

Cambridge Sensotec, manufacturers of the Rapidox range of precision gas analysers have been working with the leading AM machine manufactures for many years. High performance Rapidox oxygen gas analysis solutions are supplied for maintaining inert atmospheres within the process. OEM Rapidox oxygen gas analysers are available as a component to integrate seamlessly into any inert based AM machine.

For more information, contact the experts in oxygen gas analysis.

### How to achieve durable components with AM? The answer is Vibenite®.

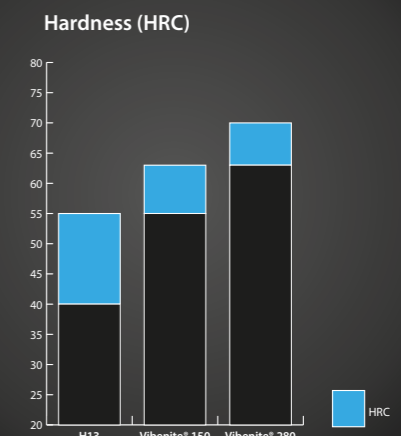

**VIBN**  
COMPONENTS

www.vbncomponents.com

## Keynote speakers announced for 2017 AMUG Conference

The Additive Manufacturing Users Group (AMUG) has announced its featured keynote speakers for the 2017 AMUG Education & Training Conference, to be held in Chicago, Illinois, USA, from March 19-23, 2017. The keynote speakers, Stacey DelVecchio, Jason Lopes and Todd Grimm, will focus on AM strategies, applications, trends and technologies.

Todd Grimm, President of T. A. Grimm & Associates and AMUG's AM industry advisor, will open the conference marking his seventh appearance as an AMUG keynote speaker. "Todd opens our conference by sharing valuable insights over a broad spectrum in a way that engages the audience and makes them comfortable with developments and issues that may challenge our members. His keynotes are perfectly

aligned with AMUG's intent – sharing information so that the right decisions can be made," stated Steve Deak, AMUG President.

Stacey DelVecchio, AM product manager for Caterpillar, will step onto the AMUG stage on Tuesday, March 21, to discuss how Caterpillar's strategy to bring 3D printing from prototype solution to manufacturing method has evolved. DelVecchio will also share how Caterpillar is leveraging its innovative incubator to "think big...start small...act fast".

Jason Lopes, of Legacy Effects, returns for his fourth AMUG keynote appearance. Spanning film, TV, Broadway and character appearances, Lopes' work pushes the limits of the technology to make amazing physical effects a reality. In his presentation, he will share the tools he has used, the creativity employed

and the amazing results that were achieved. Lopes' film credits include Avatar; Ironman 1, 2, 3; Avengers 1, 2 and the upcoming third; Pacific Rim and Jurassic World.

"For Jason's keynote, we have a new twist this year. He will begin his visual journey of his use of additive manufacturing for special effects on Monday; continue with video shorts on the following days; and then wrap up on Thursday with a Q & A session. The goal is to illustrate the amazing things the company does and how it selects the right technology for the job," stated Deak.

The AMUG Conference will also feature the Innovators Showcase, which is an on-stage conversation with Carl Deckard, inventor of Selective Laser Sintering (SLS) and Chief Technology Officer for Structured Polymers. The conference will also include over 200 presentations, workshops and hands-on training sessions.

www.am-ug.com ■■■

## Sigma Labs receives Phase III DARPA contract with Honeywell

Quality assurance software provider Sigma Labs, Inc., based in Santa Fe, USA, has announced that it has received a contract from Honeywell Aerospace as part of a previously announced award with the Defense Advanced Research Project Agency (DARPA) for Open Manufacturing (OM) Phase III. The DARPA OM programme's goal is to develop an Integrated Computational Material Engineering (ICME) framework to accurately predict the properties of metal components produced using Additive Manufacturing.

Phases I and II of the programme were completed in 2014 and 2016 respectively and the Phase III work will run through until mid-2018. A total award value of approximately \$400,000 has been allocated to Sigma Labs.

"We are very pleased to have once again been selected for a follow-on contract with Honeywell as part of their DARPA OM award," stated Mark Cola, President and Chief Executive Officer of Sigma Labs. "Having successfully completed the Phase II piece of the program earlier this year, we look forward to working with Honeywell and its team to further demonstrate how our PrintRite3D® technology enables rapid manufacturing processes such as laser-based 3D printing for precision metal components. Through this award, we'll have the opportunity to demonstrate how our PrintRite3D® software can be a key enabler for developing quality assurance standards for metal AM aerospace components."

DARPA created the Open Manufacturing program to lower the cost and speed the delivery of high-quality manufactured goods with predictable performance.

www.darpa.mil/program/open-manufacturing  
www.sigmalabsinc.com ■■■

## European AM Group renamed EuroAM

The European Powder Metallurgy Association has announced that as of January 2017 its European Additive Manufacturing Group (EAMG) will be renamed EuroAM. The sectoral group will continue to cover the same industry sector as the EAMG, focussing on metal Additive Manufacturing. The change of name is an attempt to further raise awareness of the group and its activities on a Europe-wide basis. Members of the EAMG felt that the current group name did not reflect this strategic objective strongly enough.

The group is co-chaired by Ralf Carlström, Höganas AB, Sweden, and Claus Aumund-Kopp, Fraunhofer IFAM, Germany. Areas of activity for the group include promotion, research & technology development, training and standardisation.

www.epma.com/european-additive-manufacturing-group ■■■

simufact additive

## Simufact Additive helps you produce Metal AM parts

„Right the First Time“

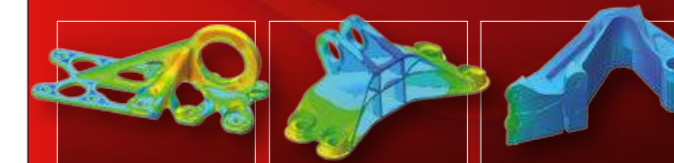
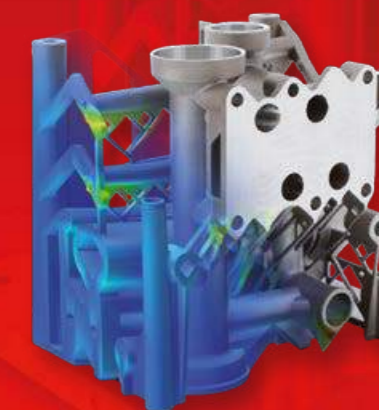

### Determine and reduce final part distortion

- ◆ Determine and reduce final part distortion
- ◆ Minimize residual stress
- ◆ Optimize build-up orientation and support structures
- ◆ Condition the part after heat treatment, base plate/ support structure removal, and Hot Isostatic Pressing (HIP)
- ◆ Recalculate pre-deformed part geometry

 **simufact**  
Simulating Manufacturing  
MSC Software Company

Want to learn More?

simufact.com/  
additive-more-info



New Challenge Best Quality

## Gas-Atomized Titanium Powder

# TILOP

### Titanium Low Oxygen Powder

OTC has been producing titanium powder since 1991. The manufacturing process employs the gas atomization method, which is the most suitable for mass production.

As one of the largest manufacturers of aerospace grade titanium sponge, we provide a stable supply high quality titanium powder that meets all your requirements.

#### Possible powder for production

- CP Titanium
- Ti-6Al-4V, Ti-6Al-4V ELI
- Trially produced other alloys (e.g. Ti-Al Alloys, Ti-6Al-7Nb)

#### Markets & Applications

- Additive Manufacturing (AM)
- Metal powder Injection Molding (MIM)
- Hot Isostatic Pressing (HIP)
- Others



Appearance

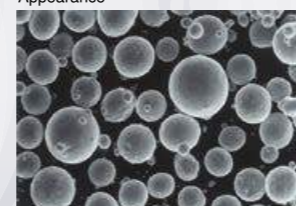

OTC

OSAKA Titanium technologies Co.,Ltd.

URL <http://www.osaka-ti.co.jp>

Contact Address Titanium Sales and Marketing Group  
Tokyo Office / Sumitomo Hamamatsucho Building 8F, 1-18-16 Hamamatsucho, Minato-ku, Tokyo 105-0013, Japan  
Tel:+81-3-5776-3103, Fax:+81-3-5776-3111

## Metals Additive Manufacturing for Aerospace & Autosport

Nickel superalloys including:  
CM247LC, Inconel 625,  
I718, Titanium alloys,  
Maraging steel, Stainless steels

### 2016 CAPACITY

9 × EOS 250×250mm  
2 × EOS 400×400mm

AS9100 Rev C  
& Major Approvals

 **Materials Solutions**

+44 (0)1905 732160  
www.materialssolutions.co.uk

## Arconic to supply nickel and titanium AM parts for Airbus aircraft

Arconic has announced it has entered into two agreements to supply Airbus with metal additively manufactured parts for commercial aircraft. The company will supply components made from high temperature nickel superalloys as well as titanium airframe parts.

"We're proud to deepen our partnership with Airbus through these agreements," stated Klaus Kleinfeld, Chairman and CEO of Arconic. "Airbus's confidence in our Additive Manufacturing capabilities is grounded in Arconic's comprehensive strengths—from aerospace know-how to metals powder production and product qualification expertise. We are pleased to support our customers and pave the way to the future of aerospace manufacturing."

Arconic will supply 3D printed ducting components made of high-temperature nickel superalloys for the A320 family of aircraft. Advanced nickel superalloys offer superior heat resistance for these components, which flow hot air from the aero engine to other parts of the airframe. Under a second deal, Arconic will supply titanium airframe brackets, also for the A320 platform.

www.arconic.com ■■■

## Höganäs joins UN Global Compact sustainability initiative

Sweden's Höganäs AB, owner of Digital Metal 3D printing technology, has reported that it has joined the UN Global Compact, the world's largest corporate sustainability initiative. Based on a set of ten principles, participants pledge to adjust their business so that they, in a sustainable way, contribute to the development of societies and economies.

"Sustainability is a strategic priority for Höganäs and by joining the Global Compact we demonstrate our clear commitment," says Nicklas Lång, Vice President and head of Höganäs' Sustainability department.

Corporate sustainability starts with a company's value system and a principled approach to doing business. Participating companies operate in ways that, at a minimum, meet fundamental responsibilities in the areas of human rights, labour, environment and anti-corruption.

"The UN Global compact does a good and important job and by us joining, we support their continuous work. At the same time, we get access to networks and tools that are of use on our own journey ahead," added Lång.

www.unglobalcompact.org  
www.hoganas.com ■■■

## SAP, EOS, APWorks, Linear AMS and Heraeus collaborate to showcase the future of manufacturing at Hannover Fair

SAP SE has announced it will showcase new technology to accelerate the adoption of Additive Manufacturing in mainstream manufacturing and supply chains at this year's Hannover Fair, taking place in Hannover, Germany, April 24- 28. In collaboration with EOS, APWorks, Linear AMS and Heraeus, SAP will demonstrate three key scenarios: highlighting the potential for seamless connectivity, collaborating in the design process and machine system management.

SAP will demonstrate how EOS machines can be connected to SAP Manufacturing Execution (ME) and SAP ERP via the SAP Plant Connectivity (PCo) solution. With this seamless connection, 3D models are transferred from SAP PLM to SAP ME/ERP and then to an EOS machine. Once the builds are processed on the EOS machine, the result of the build and any error codes are published back to SAP ME. With this seamless connectivity, customers can embed AM machines into their manufacturing setup with full visibility and control.

The company will also showcase its latest solution, SAP Distributed Manufacturing, which will help manufacturing companies collaborate with AM machine manufacturers, service bureaus and material companies through the design and quality collaboration processes. With an intuitive 3D viewer, quality collaboration modules and RFQ integration into SAP S/4 Cloud, all participants will have same view of the collaboration at any time and the streamlined way to manage this process will help them to get the parts optimised, the best material identified or even developed, the parts approved for procurement more quickly.

With an integration to a pricing service from Linear AMS, it will be shown how instant prices can be provided.

Lastly, SAP will demonstrate how AM machine manufacturers and customers can collaborate and deliver Additive Manufacturing as a service. Leveraging SAP Asset Intelligence Network (AIN), to exchange information like counter readings or error codes, EOS will showcase how it can manage its AM machines leased out at multiple service bureaus such as APWorks and Linear AMS. Through SAP Asset Intelligence Network, all participating companies will have full visibility of the usage, capacity and availability of the AM machines and other related equipment. With the new level of visibility, EOS can now monitor the health of the AM machines and provide help and needed maintenance before any problems occur at customer sites. SAP will be at Hall 7, Stand B04 at Hannover Fair.

www.sap.com/3dprinting ■■■



**AddUp**  
GLOBAL ADDITIVE SOLUTIONS



FormUp™ 350

Design  
to fulfil **real**  
industrials issues

contact@addupsolutions.com

www.addupsolutions.com

   
AddUp, Joint-Venture of Fives Group and Michelin



## QuesTek to optimise legacy alloys and design new alloys tailored for AM

QuesTek Innovations, LLC, Evanston, Illinois, USA, has been awarded six separate projects from the US Navy and US Army to develop technologies and design new alloys specifically tailored to the unique processing conditions and material-related challenges of Additive Manufacturing. These include three Small Business Technology Transfer (STTR) Phase I projects focused on aluminium, titanium and steel systems. The combined funding contract value exceeds \$2 million.

QuesTek states that there is increasing interest in the development of new alloys specifically tailored for AM, as well as a need for understanding the complex processing responses and limitations of traditional forging and cast alloys applied to AM processing. Most alloys being evaluated in AM were, however, originally designed for forging or casting processes and exhibit technical problems when used in AM. To address these unique design challenges and industry needs, QuesTek has been applying its Integrated Computational Materials Engineering (ICME) technologies and Materials by Design® methodologies to design entirely new alloys and optimise legacy alloys for Additive Manufacturing.

Under an Office of Naval Research (ONR)-funded Phase II SBIR project (Topic N141-062) titled "Computational Design of Aluminium Alloys for use in Additive Manufacturing," QuesTek is furthering the development of three QuesTek-designed aluminium alloys specifically for Direct Metal Laser Sintering processability. The goal of this programme is to combine the processability of AlSiMg alloys, which can be printed without cracking but have low strength, with the high strength properties of 6061/7050 alloys but which crack during AM processes.

Under a U.S. Navy Phase I STTR project (Topic N16A-007) titled "Optimised High Performance Stainless Steel Powder for Additive Manufacturing," QuesTek is developing a new powder specification for high-strength martensitic precipitation-hardenable 17-4 stainless steel, optimised specifically for SLM technologies, to meet mechanical performance requirements and address AM processing issues experienced by incumbent materials.

In a further programme, QuesTek is collaborating with LPW Technology, Dr Thomas Starr of the University of Louisville's Rapid Prototyping Centre and OEM partner Sikorsky Aircraft.

QuesTek is developing an "Integrated Model Toolkit" that enables the modelling of AM process by predicting local composition, microstructure, residual stresses, defects and mechanical properties for stainless steel 316L aerospace components for an ONR-funded Phase I STTR project (Topic N16A-022) titled "Integrated

Computational Material Engineering Tool Set for Additive Manufacturing of Stainless Steel (316L)." For this programme, QuesTek is collaborating with Professor Wayne E King of Lawrence Livermore National Laboratory and Professor Gary Harlow of Lehigh University.

Under a US Army Phase I SBIR project (Topic A15-104) titled "Application of ICME to Optimise Processing of State-of-the-art Gear Steels in Additive Manufacturing," QuesTek atomised, built via LENS and DMLS AM processes and evaluated its high-performance carburisable Ferrium® C64® steel. The goal of this initial programme was to develop and optimise an AM technique and post-build treatment process specifically for C64 steel while meeting or exceeding the material performance of existing high performance aerospace gear materials such as AMS 6308 manufactured using traditional metallurgical routes.

QuesTek is extending its ICME tools to evaluate materials for the DMLS production of heat exchangers in an ONR-funded Phase I SBIR project (Topic N161-071) titled "Additive Manufacturing Development of Naval Platform Heat Exchangers." The project includes fabrication of test specimens to address one of the unique challenges to AM of heat exchangers: minimum component thickness.

A US Navy Phase I STTR project (Topic N16A-004) titled "Quantifying Uncertainty in the Mechanical Performance of Additively Manufactured Parts Due to Material and Process Variation," sees QuesTek extend the Accelerated Insertion of Materials (AIM) framework for managing the uncertainty of material properties to the mechanical performance of laser power bed additively manufactured Ti-6Al-4V materials. The goal of the programme is to develop a tool which can determine both property probability distributions and probability-distribution confidence intervals for AM parts, thereby greatly accelerating aerospace certification and flight qualification of AM parts. Under this program, QuesTek is collaborating with Professors Gary Harlow of Lehigh University and Peter Collins of Iowa State University.

In addition to the above, QuesTek has been active on many other projects including modelling of Ni-, Ti- and W-based alloys for AM. Under Lockheed Martin funding, a titanium alloy that QuesTek designed under US Army SBIR funding (Topic # A082-050) demonstrated greater strength and toughness versus traditional Ti-6-4 in Electron Beam Additive Manufacturing (EBAM) processing at Sciaky and shows great potential for powder-based AM applications.

"A materials-based approach to addressing the challenges of AM is crucial for accelerating the development of this technology and achieving, or even surpassing, the performance of traditionally-processed alloys. We look forward to the outcomes of these projects, and the prospect of adopting ICME-designed alloys as the first-generation, high-performance AM materials," stated Aziz Asphahani, QuesTek's CEO.

www.questek.com ■■■

**西安欧中材料科技有限公司**  
Sino-Euro Materials Technologies of Xi'an Co.,Ltd.

## Specialized in Powder

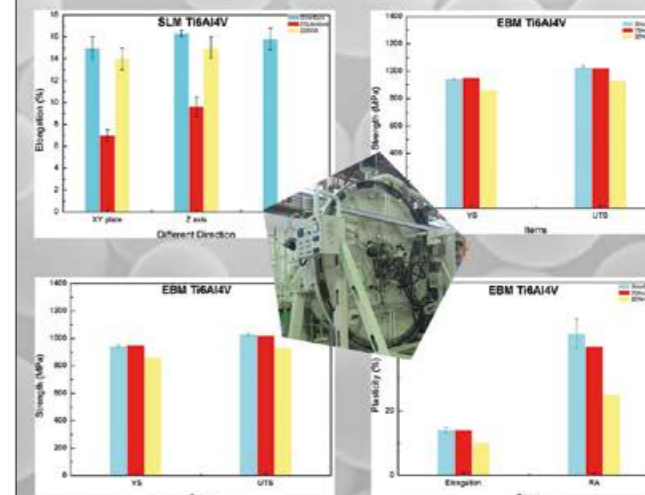

## SMT SS-PREP Powder

- CP Titanium
- Ti-6Al-4V Grade 5 & 23
- BT20(TA15)
- In718,EP741NP,Hastelloy
- Co-Cr-W,Co-Cr-Mo
- Specialty steel 17-4PH, AF1410

## Powder characterization

- Spherical
- Satellite-free
- Non-hollow
- High Flow Rate

[www.c-semt.com](http://www.c-semt.com)

market@c-semt.com

market\_@hotmail.com

Tel:+86 29 86261802



## **PTI** HOT ISOSTATIC PRESSING for Additive Manufacturing

### Improving Product Lifespan and Consistency for 3D Printed Metal Parts

- Aerospace
- Electronics
- Ten (10) Units to 30" Diameter & 108" Long
- Automotive
- Oil & Gas
- Pressures to 30,000 psi (207 MPa)
- Biomedical
- Power Generation
- Temperatures to 2550° F (1400° C)



Pressure Technology, Inc.  
Warminster, PA | 215-674-8844  
Concord, OH | 440-352-0760

[www.pressuretechnology.com](http://www.pressuretechnology.com)



## AMPM2017 conference programme published and student grant support announced

The Metal Powers Industry Federation (MPIF) has published the Conference Programme and opened registration for AMPM2017, Las Vegas, Nevada, USA, June 13 – 15, 2017. The fourth annual Additive Manufacturing with Powder Metallurgy conference will feature over 70 technical presentations from worldwide industry experts on the latest developments in the fast-growing field of metal Additive Manufacturing.

"Over the last several years, AMPM conferences have become a critical resource for anyone interested in the development of materials, applications and process economics relating to the metal AM world," stated Dan Messina, Technical Manager, MPIF.

The conference opening general session will feature a keynote presentation from Todd Grimm, T.A. Grimm & Associates, on 'Navigating the Metal Additive Manufacturing Landscape'. The author will blend industry updates, trends and insights, helping to cut through the hype and identify when, where and why metal Additive Manufacturing makes sense.

AMPM2017 shares several events and an exhibit hall with the co-located POWDERMET2017, the International Conference on Powder Metallurgy and Particulate Materials, where more than 100 exhibitors will showcase PM and metal AM processing equipment, powders, and products.

### Grant programme to support students attending show

The US National Science Foundation has announced the approval of a grant programme to support forty students from US institutions to attend the AMPM2017 and POWDERMET2017 conferences. The awards will cover the full conference registration fee and a three-night hotel accommodation.

"We continually see that there is a shortage of skilled workers. This is a huge opportunity for students interested in pursuing careers in engineering or materials science," stated MPIF Executive Director and CEO Jim Adams. "Students will be able to meet and learn from some of



The conference will be held at the Bellagio Hotel in Las Vegas

the best engineers and component designers in the industry by attending technical sessions, special interest programs, walking the exhibition hall, and networking during industry luncheons and evening events."

The MPIF expressed its gratitude to the National Science Foundation for its support of students to attend the POWDERMET2017 and AMPM2017 annual conferences. The support provides student participants with opportunities to exchange ideas with leading researchers and engineers from worldwide industrial and governmental facilities, as well as with students and faculty from both domestic and international universities.

[www.mpif.org](http://www.mpif.org)  
[www.ampm2017.org](http://www.ampm2017.org) ■■■

**Outstanding results in heat treatment**

Individual solutions for the needs of additive manufacturing heat treatment  
 best for sintering & debinding, annealing and powder treatment

**MUT** ADVANCED HEATING AM additive manufacturing - A new chance in powder metallurgy

[www.mut-jena.de](http://www.mut-jena.de)



Be Industrial  
 Be Adaptable  
 Be Innovative



**BeAM Machines**  
**DED (Directed Energy Deposition)**  
[www.BeAM-Machines.com](http://www.BeAM-Machines.com)  
[contact@beam-machines](mailto:contact@beam-machines)

## BeAM Additive Manufacturing opens US office

BeAM, a French manufacturer of industrial metal Additive Manufacturing machines using Directed Energy Deposition (DED), has opened a US subsidiary, BeAM Machines, Inc., in Cincinnati, Ohio. The new 20,000 ft<sup>2</sup> facility will handle sales, service, process development, applications, research & development and training, and will operate as the BeAM Solutions Center for North America.

Tim Bell has been appointed as General Manager for the new facility. "I am excited to introduce American companies to BeAM's DED technology. Our ability to provide solutions that meet our customers' needs is the result of design and manufacturing through a system of collaboration, feedback and experience across multiple industries including aeronautic, aerospace, defence, nuclear, and oil & gas. And our solution-

oriented support minimizes both technological and financial risks for these customers, while maximizing their competitive advantage through innovation," stated Bell.

"Opening a US Subsidiary is a major milestone, given the prospects for robust and rapid growth harboured by the American market. BeAM intends to become a major player in the US, which has become the world leader in Additive Manufacturing," stated BeAM's CEO Emeric d'Arcimoles.

BeAM's Additive Manufacturing machine solutions include the new Mobile, optimised for small and medium production volumes as well as the repair of thin and complex parts. The company also manufactures the Magic 2.0, a large scale five axis machine designed for serial production or repair of high value

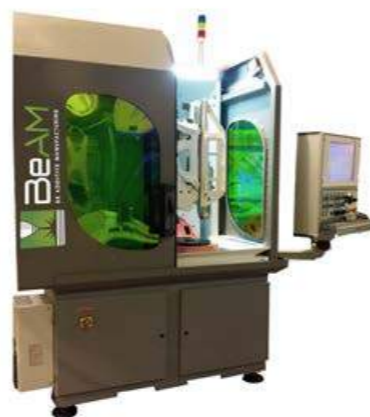

BeAM's Mobile AM machine is optimised for small and medium production volumes

components in industries with long lead times and high buy-to-fly ratios, and the new Modulo, a smaller fully integrated five axis serial production machine ideal for constrained space environments or even used in remote places such as oil rigs, military conflict zones, etc.

www.beam-machines.com ■■■

## Bodycote site earns highest aerospace accreditation

Bodycote, the world's largest heat treating services provider, has announced that its Chesterfield, UK, Hot Isostatic Pressing (HIP) facility has once again earned the highest level of Nadcap accreditation following a recent Nadcap audit. The official approval was awarded on 2 February, 2017.

As one of the original HIP facilities to achieve this standard, the company is now targeting to further extend its Merit status. This is building on a long history of supplying Hot Isostatic Pressing to the world's aerospace prime manufacturers and their first tier suppliers.

Hot Isostatic Pressing ensures that any porosity within an additively manufactured component is removed, thereby reducing the variation in mechanical properties when compared with the as-built part, as well as improving ductility and fatigue strength.

Moving forward, Bodycote stated that the Chesterfield site continues to play a strategic, long term role for new aerospace high technology programmes. The company added that it will continue to invest in resources and capital for development and operations to meet the demands required for this future growth.

www.bodycote.com ■■■

## Farsoon Technologies announces new metal AM machine

Farsoon Technologies has announced its new FS271M metal Additive Manufacturing machine aimed at demanding applications in the aerospace, automotive and medical sectors. Incorporating a 500W Yb-fibre laser, the new system offers high-accuracy custom scanning algorithms and a 275 x 275 x 320 mm build area.

The FS271M offers complete access to machine parameters and settings, offering customers the choice of utilising Farsoon materials or the wide range of third-party materials available. In addition to fabricating nearly any metal powder, the FS271M incorporates the latest safety systems with inert gas supply and over-sized protective filter systems.

Hunan Farsoon High-tech Co., Ltd, headquartered in China, was founded in 2009 and specialises in the development and manufacture of Selective Laser Sintering (SLS) equipment and materials. The company's open platform strategy allows for complete freedom to operate with any open platform application or development programme.

www.farsoon.net/metals-systems ■■■

# ARGON **inert** MANAGEMENT

## SAFETY SAVINGS

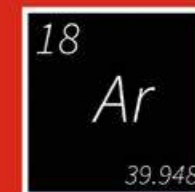

## TRACEABILITY

### Inert-AM.com

inerttechnology.com

info@inerttechnology.com

+1-978-462-4415

inert-corp







**We build atomizing equipment**  
for close-coupled and free fall gas atomization of  
Titanium • Inconel • Tool Steel • Aluminum  
and more

**Toll material processing**  
Powder • Castings • Refining of reactive  
and refractory metals using cold crucible,  
ceramic and graphite furnaces

**Arcast Inc.**  
WWW.ARCASTINC.COM  
SALES@ARCASTINC.COM



## Austrian conference highlights innovations in metal Additive Manufacturing

The Metal Additive Manufacturing Conference, MAMC2016, took place November 24-25, 2016, at voestalpine Stahlwelt in Linz, Austria. The two day event was the second in the series organised by the Austrian Society for Metallurgy and Metals (ASMET) and attracted over 220 participants from some 16 countries. The following review, written by Prof Dr Bruno Buchmayr, Montanuniversität Leoben and Prof Dr Jürgen Stampfl, TU Vienna, reports on the event and highlights some of the key presentations.

The technical programme consisted of 35 oral presentations and identified the latest trends and innovative developments along the entire Additive Manufacturing process chain, as well as numerous novel applications. The opportunities connected with such a dynamic technology raises interest in the materials and equipment industries, and indication of the relevance of AM for Austrian industry was given in the opening presentation by Franz Rotter, Head of voestalpine's Special Steel Division and President of ASMET. Rotter discussed his clear focus on metal Additive Manufacturing, not only with the installation of an AM centre in Düsseldorf in April 2016,

but also by offering new AM metal powders to the market.

### Overview of AM processing

Prof R Poprawe, head of the Chair for Laser Technology at RWTH Aachen, presented a keynote paper that gave an overview of the role of Additive Manufacturing technologies within the envelope of Technology 4.0. Poprawe illustrated the RWTH view on Integrative Production Technology and explained the basics of laser technology at its interaction with the different materials. He presented some examples on graded materials, for example with a ductile core and wear resistant surface, as well as hybrid materials, such as Stellite on copper alloy.

Also discussed were hybrid machine concepts, such as the DMG Mori Lasertec concept, and high speed LMD, using primary energy deposition into the powder, for large components. The move from prototyping to first series production of a large scale motor block was highlighted, along with other interesting new applications. Typical AM examples in the automotive industry were shown (Fig. 1).

Bionic inspired designs, such as lightweight structures, demonstrated

to the audience the significantly enhanced design freedom that Additive Manufacturing can offer compared to traditional manufacturing technologies. Ideally, such designs could result from a process where the functionality of the component is specified and the production system designs the product, chooses the material and manufactures the component.

The author stated that integrative research needs knowledge on material, processes, machines, product design and business models. The functionality needs to be translated into a design, addressing the geometry and the material properties. Increasing productivity via multiple laser sources, higher laser power, application of a skin-core principle and new exposure concepts, can all help to reach this goal.

### Market situation

Benedikt Blitz from SMR Premium provided an interesting overview of the market situation for metal powders. Blitz said that despite impressive growth numbers for AM, and metal AM in particular, the total numbers are still small compared to other metal powder technologies such as press and sinter Powder Metallurgy, HIP and MIM. The analysis showed that although the AM powder market achieved sales of \$90 million in 2015, this only represented about 1% (in weight) of the overall worldwide powder market. Interestingly however, it was shown that AM growth is much faster when compared to HIP and MIM, especially in the last two years. Blitz also showed the price range of different metal powders and concluded that the powder price could be around 50% lower in the next ten years.

### Ni and Fe based alloys processed by Additive Manufacturing

In a further keynote presentation, Prof Dr Thomas Niendorf from Kassel University presented detailed investigations using TEM, EBSD and IPE processes. For steel grade AISI-316L he explained the quantitative difference on service properties, such as

fatigue limit, based on the processing conditions; for example, the fatigue limit increased in the sequence: as-built/SLM surface, as-built/turned surface, 650°C/turned surface and HIPed/turned surface. Using X-Ray diffraction, residual stresses were measured in all three directions, with the highest internal stresses found for y-direction (the building direction).

As-built and heat treated samples showed elongated grains in the building direction with a strong texture. This microstructure changed significantly after a HIP-treatment, which led to almost equiaxed, coarse grains without any texture. Prof Niendorf also showed interesting creep curve results for SLM-nickel-base-alloy IN718 with superior creep strength.

### Process Simulation

Jonas Zielinski, ILT/RWTH, and colleagues investigated numerically the spatial distribution of individual particles and used two different methods, a) a discrete element method and b) a volume-to-fluid

method (melting of the powder particles and solidification to a solid). The results provided insights on how the powder bed packing density affects the AM process and the final product quality. The melted area along a single track is shown in Fig 2.

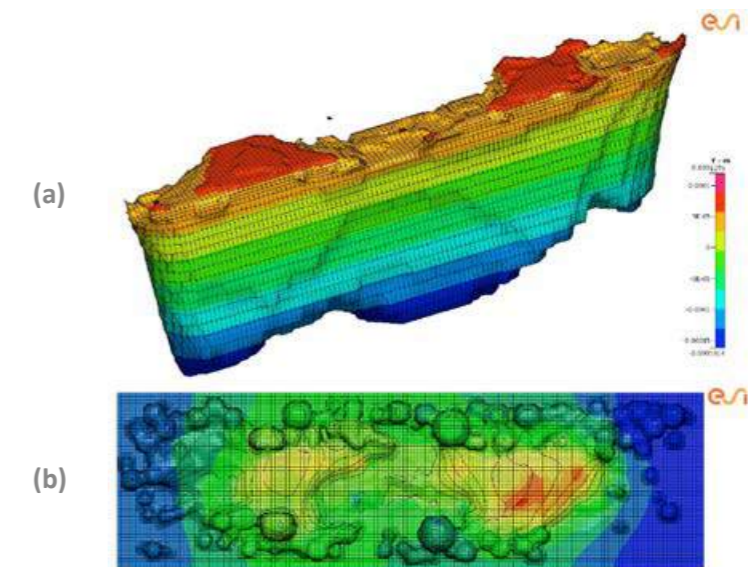

Fig. 2 (a) melted volume along a single track; (b) top view of the same track

### Topology optimisation and lattice structures

The basics and the strength of different approaches to topology optimisation were comprehensively explained by Alexander Walzl

...continued over page

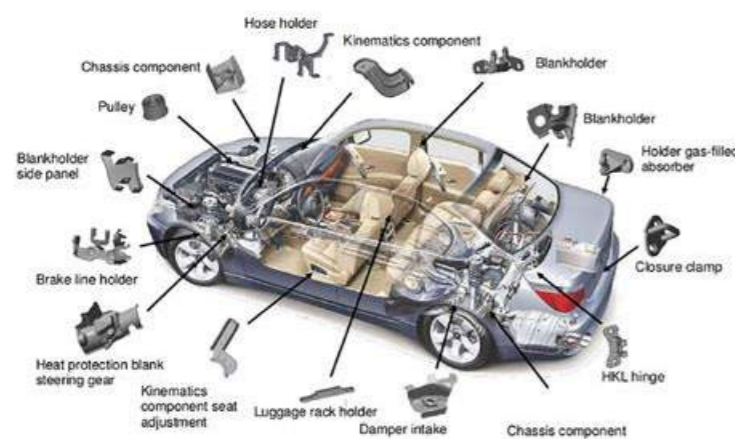

Fig. 1 Additive Manufacturing, automotive examples [Source: N.Skrynecki, Kundenorientierte Optimierung des generativen Strahlschmelzprozesses, 2010]

THE NEXT INDUSTRIAL REVOLUTION  
**STARTS HERE**

Pearl Micro® metal powders

NEW  
EN 9100 certification

**ADDITIVE MANUFACTURING**

- Nickel & Cobalt base superalloys, steels, other specialty alloys
- Selective laser melting, electron beam melting, laser metal deposition
- Customized particle size
- VIM gas atomization process

PEARL Micro

Contact  
powder@eramet-erasteel.com  
www.aubert-duval.com - www.erasteel.com

AUBERT DUVAL ERASTEEL

of Montanuniversität Leoben. Walzl explained that the different optimisation methods need specific parameters to be successful. The final optimised, complex geometries are however not always producible in a conventional way and that is why AM has a superior position.

Additional case studies with high commercial potential were shown by David Schäfer, FIT Production GmbH. Schäfer also mentioned the balance between cost and benefits especially when they are compared with conventional manufacturing processes. Design aspects are not enough however, there is also a need for support minimisation and reduction of machine cost, which contributes to about 80% to the overall costs. The scrap proportion has to be kept below 30%. Quality assurance measures and data analysis as well as testing (CT scan) are all part of the game, he said.

Karl Neulinger, AIM Sweden AB, highlighted EBM applications and explained the pros of the

ELISE concept, a tool for topology optimisation. Similar examples were shown by Stephan Ziegler, ILT/RWTH Aachen, where lattice structures as well as hollow sphere structures were made out of steel. The values for stiffness and specific energy absorption were evaluated for different wall thicknesses and cell sizes to determine scaling laws for practical applications.

#### Conclusion

When compared to the MAMC conference in 2014 it was clear that there has been significant progress regarding materials, understanding of the AM process and exploitation of new applications. For lightweight applications, such as those in the aerospace and space sector, there can be a clear argument for using metal Additive Manufacturing. Topology optimisation, in combination with lattice structures, offers outstanding solutions for many lightweight constructions.

The final decision between

conventional manufacturing processes and AM is, for many, still a matter of economics. However, as recent presentations show, there is a significant increase of effort in all fields to promote AM for many interesting applications.

Details of the presentations can be found in the conference proceedings, which can be ordered from ASMET secretariat (Yvonne.Dworak@asmet.at). The third MAMC conference will be November 20-22, 2018 in Wr. Neustadt, Austria.

#### Authors

*Prof. Dr. Bruno Buchmayr is head of Chair for metal forming at Montanuniversität Leoben, Austria. Tel.: +43-3842-402-5600 Email: Bruno.Buchmayr@unileoben.ac.at*

*Prof. Dr. Jürgen Stampfl is leading an AM-group within the Institute for Materials Science and Technology at TU Vienna, Tel.: +43-1-58801-30862 Email: Juergen.Stampfl@tuwien.ac.at*

## New High Performance Alloys Designed for Additive Manufacturing

Aluminum, nickel, titanium, stainless steel, high performance steel,  
and other computationally-designed alloys

Alloy Design • Legacy Alloy Optimization • Microstructural Modeling  
Process Optimization • Contract Manufacturing

Industry has realized that using off-the-shelf legacy alloys in additive processes presents challenges. As global leaders in Integrated Computational Materials Engineering (ICME), QuesTek is at the forefront of computationally designing novel materials specifically for additive manufacturing processes. Contact us to address your additive materials issues.

**QUESTEK®**  
INNOVATIONS LLC

Contact Jeff Grabowski, Manager of Applications  
(847) 425-8241 | jgrabowski@questek.com  
1820 Ridge Avenue, Evanston, IL, USA 60201

## International conference on titanium PM and AM seeks abstracts

Organisers of the 4<sup>th</sup> International Conference on Titanium Powder Metallurgy & Additive Manufacturing have issued a Call for Papers. The conference series has been successfully held in Australia, New Zealand and Germany and in 2017 will take place in Xi'an, China, September 8-10, 2017. The conference will be held in the Grand New Century Hotel and is hosted by the State Key Laboratory of Porous Metal Materials, Northwest Institute for Non-ferrous Metal Research, China.

"The PM Titanium conference series has been successfully held in Australia, New Zealand and Germany in the last 5 years. Now we are pleased to host the next wonderful conference set for 8-10 September 2017 in Xi'an, P.R. China. It is quite fruitful for the experts in PM Ti areas around the world to share, discuss and exchange their knowledge, understanding and experience again. All scholars and experts related to titanium Powder Metallurgy and Additive Manufacturing are welcome to come and attend this PMTi 2017 conference," stated Conference Chair, Huiping Tang.

www.tipmam2017.org ■■■

## Lucideon teams up with America Makes

Lucideon, a materials technology company based in Raleigh, North Carolina, USA, with facilities in Schenectady, NY, Greenville, SC, and the UK, has announced it has joined with America Makes to offer members a range of materials, component and process testing, validation and analysis.

As the USA's national accelerator for AM, America Makes is a leading and collaborative partner in AM technology research, discovery, creation and innovation. Structured as a public-private partnership with member organisations from industry, academia, government, non-government agencies, and workforce and economic development resources, its aim is to innovate and accelerate AM and to increase the United States' global manufacturing competitiveness.

Lucideon has a backbone in technology development, R&D and testing and assurance, it has a team of experts who specialise in supporting manufacturers throughout the AM supply chain.

"We are delighted to be able to partner with America Makes, an organization that is leading the way in AM research and innovation," stated Brent Holloway, Lucideon's Director of Sales & Marketing.

www.lucideon.com/am  
www.americamakes.us ■■■



You ...

want fine particles to be removed – not only limited? ✓

want your own powder – not an ordinary composition? ✓

**NANOVAL – Specialist  
for Specialty Powders**



We ...

offer outstanding flowability, no fines due to air classification!

produce the composition you want, you can include:

Ag, Al,  
Au, B, Ba, Bi, C, Ce, Co,  
Cr, Cu, Fe, Ga, Gd, Hf, In, Ir, La,  
Li, Mg, Mn, Mo, Nb, Nd, Ni, P, Pb,  
Pd, Pt, Re, Rh, Ru, Sb, Sc, Se, Si,  
Sm, Sn, Ta, Te, Ti, V, W, Y,  
Zn, Zr

Nanoval GmbH & Co. KG  
Kienhorststrasse 61 – 65  
D-13403 Berlin

Phone: +49 30 3 22 90 22-0  
info@nanoval.de  
www.nanoval.de

**PSI Limited**  
Advanced Process Solutions

**We make the systems ...**

**... that make the powders ...**

**... that make the headlines**

GKN Aerospace to lead research titanium powder for aerospace c

The TIPOW program... effective re-use and recycling material and a study of potential applications for the recycling of titanium powder.

Johnson Matthey employees in Centre (JMTC). "To date research into Additive Manufacturing (AM) largely on evolving the require to enter full scale production of these processes are a breakthrough, the quality of the parts is excellent." EPMA, ICPMS, SEM, XRF, XRD, DSC, TGA, TMA, etc. excellent facilities to provide analysis of glasses, additives and other materials with photovoltaic properties.

**PSI Limited - Apex Business Park**  
Hailsham - East Sussex - BN27 3JU - UK  
Tel: +44 (0)1323 449001  
info@psiltd.co.uk - www.psiltd.co.uk

## MachineWorks teams with Stratasys to integrate Polygonica software

MachineWorks Ltd, based in Sheffield, UK, has announced a new partnership with Stratasys Ltd in which the company's Polygonica software will now work seamlessly inside Stratasys GrabCAD Print, enabling automatic mesh repair, mesh offsetting, Boolean operations and analysis functions.

Claimed to make Additive Manufacturing easier and more accurate, GrabCAD Print resides on the popular SaaS platform and is powered by a new 'design-to-3D print' workflow application. The software will now incorporate Polygonica mesh libraries. Dr Fenqiang Lin, MachineWorks Managing Director, stated, "GrabCAD and Polygonica share the same philosophy of enabling a single 'click-to-print' methodology for 3D models, in the same way we do with 2D printing. The user doesn't want or need to know about what software is used to prepare the file, they just want their CAD model printed with the minimum of fuss."

Polygonica's mesh repair functions ensure models are closed and watertight, free of self-intersections, badly

oriented triangles, noise shells and non-manifold edges. The algorithms can be applied either fully or semi-automatically to ensure minimal disruption to the printing workflow. Robust Boolean and offsetting operations are vital for preparation tasks such as splitting models, engraving meshes, hollowing and infilling meshes; Polygonica analysis tools such as optimal orientation and clash detection can be used for build plate optimisation.

"MachineWorks has set an industry standard for CNC simulation and verification software - backed by its robust Polygonica solid modelling toolkit for processing polygon meshes," stated Jon Stevenson, Senior Vice President Global Software, Stratasys. "Combined with the power of GrabCAD Print to streamline and simplify the 3D printing process, customers can dramatically enhance 3D printing design freedom and creativity to accelerate the prototyping, tooling and manufacturing process."

www.polygonica.com  
www.stratasys.com ■■■

## Gramm launches interactive online course for Additive Manufacturing

Gramm, a new learning solutions provider based in Regensburg, Germany, has launched an interactive online course for Additive Manufacturing. The course is claimed to be able to teach the basics of industrial 3D printing over six hours through the use of webinars.

"We saw the rapid growth of industrial 3D printing and realised that, in order to be successful, people would need to learn more about it, so we created a course for Additive Manufacturing and put it online" stated Harald Schmid, Co-Founder and CEO of Gramm.

Gramm states that a live course is a robust teaching method and a great way to learn. Taking the course online saves both time and money for both the presenter and the participants.

The course covers the Additive Manufacturing process and design for Additive Manufacturing. Participants take part in the course by joining a webinar. They receive study materials and a personalised and signed certificate. The entire course lasts six hours and is offered several times every week.

www.gramm.online ■■■

# METAL 3D PRINTER



## PBF / Binder Jetting / Hybrid

- Many metal and sand 3D printers have been installed in Korea, Japan, and other countries.
- PBF type of metal and sand 3D printers
- A large size (1,800 x 1,200) 3D printer in binder jetting type is being developed
- The hybrid type of printer for one-time milling after 10 additive manufacturing will be developed and marketed.

## Optimized AM Solution

- High performance comparing to the price
- Built-in vacuum pump
- The same performance as the existing machine (using the same H/W parts)



### METAL SENTROL 3D SM250

Production Size (mm)	250×250×320
Laser Power (W)	200 / 400
Layer Thickness (µm)	20 ~ 40
Laser Wavelength(µm)	1.06 (Fiber)

### SAND SENTROL 3D SS600

Production Size (mm)	600×400×400
Laser Power (W)	40 / 100
Layer Thickness (µm)	200 ~ 300
Laser Wavelength(µm)	10.6 (CO <sub>2</sub> )

## SENTROL CO., LTD.

Seoul Head Quarter

Rm. 1413, 1513~1517, 278 Beotgot-ro(Gaechon-dong), Geumcheon-gu, Seoul, Korea, 08511  
Tel. 82-2-3397-5800 Fax. 82-2-3397-5801 E-mail. sentrol@sentrol.net Recruiting distributors. 82-2-3397-5833

www.sentrol.net

## Metal Powder Industries Federation appoints new Executive Director

The Metal Powder Industries Federation (MPIF) and APMI International (APMI) have formally confirmed that James P Adams has succeeded C James Trombino as its Executive Director and CEO.

Adams has worked in the Powder Metallurgy industry for more than 30 years following graduation from Hennepin Technical College in 1985. He began his career with MPIF in 2004 as Director of Technical Services, working closely with the MPIF Technical Board, where he has been responsible for Federation publications, professional development programs and conference technical programming. Under his direction, the Metal Injection Moulding and Additive Manufacturing with Powder Metallurgy conferences were developed. He has also served

as administrative director for APMI International and the Center for Powder Metallurgy Technology (CPMT).

Adams took on additional roles as administrative director for the Powder Metallurgy Parts Association (PMPA), Metal Powder Producers Association (MPPA), Powder Metallurgy Equipment Association (PMEA), and Isostatic Pressing Association (IPA), all affiliated associations within the MPIF umbrella. Additionally, he has also been MPIF's representative for the Lightweight Innovations for Tomorrow, a National Network for Manufacturing Innovation Institute, to aid in the promotion of lightweight technology development.

"MPIF has been a global leader and voice for the North American Powder Metallurgy industry for



James P Adams is the MPIF's new Executive Director and CEO

nearly 75 years and to be its fourth Executive Director is an honour and privilege," stated Adams. "Jim Trombino has left MPIF positioned for the future and I look forward to serving the current industry while advancing emerging technologies such as metal Additive Manufacturing."

[www.mpif.org](http://www.mpif.org) ■■■

Trust | Technology | Turnaround

# test, analyze, characterize for additive manufacturing

Visit Us at:  
**RAPID**  
Booth 2250  
May 8-11  
Pittsburgh, PA

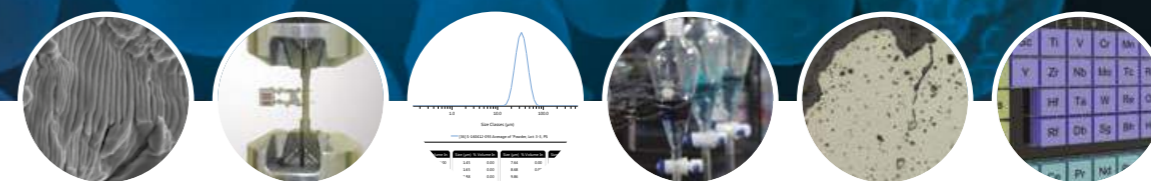

### Validating Powders, Products & Feedstock

Since 1945, NSL Analytical has helped customers verify the highest standards of materials quality, performance and safety in their products. Customers trust us with their most critical materials testing needs.

### NSL supports innovation by testing powder metal, feedstock, prototype designs and final product in the Additive Manufacturing Industry

- Chemical Composition – Analysis of major and trace level elements for R&D and Specification conformance
- Powder Characterization – Flow Rate, Particle Size Distribution and Particle Shape
- Metallurgical Analysis – Grain Structure — Mechanical Testing — Failure Analysis

Trust NSL, contact us at  
[NSLanalytical.com/industries/additive-manufacturing](http://NSLanalytical.com/industries/additive-manufacturing)  
or call **877.560.3875**



**NSL Metallurgical**  
4535 Renaissance Parkway  
Cleveland, OH 44128  
**216.475.9000**

**NSL Analytical**  
4450 Cranwood Parkway  
Cleveland, OH 44128  
**877.560.3875**

At CTC, Innovation and Technology are **Concurrent.**

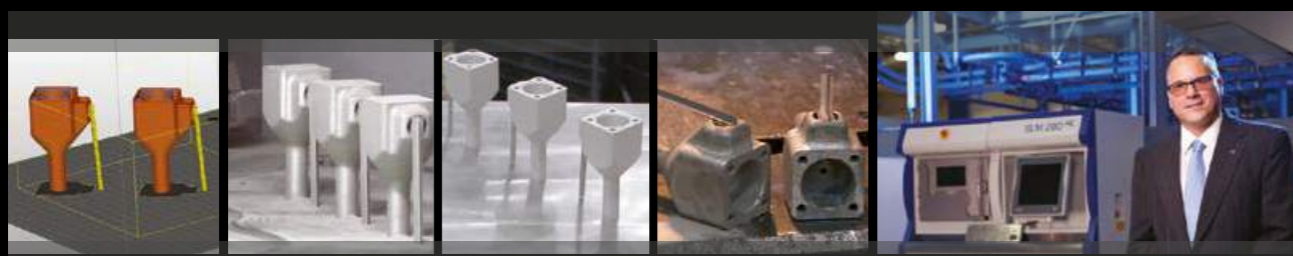

## Advancing Real-World Additive Manufacturing

- Part Identification
- Reverse Engineering/Solid Modeling
- Prototype and Part Manufacturing
- Performance/Mechanical Testing
- Design Allowables and Qualification
- Equipment Selection and Transition



Concurrent Technologies Corporation

[www.ctc.com](http://www.ctc.com)



For more information, contact Ken Sabo:  
Telephone: +1-814-269-6819  
Email: [additive\\_manufacturing@ctc.com](mailto:additive_manufacturing@ctc.com)

© 2015, Concurrent Technologies Corporation. All Rights Reserved.

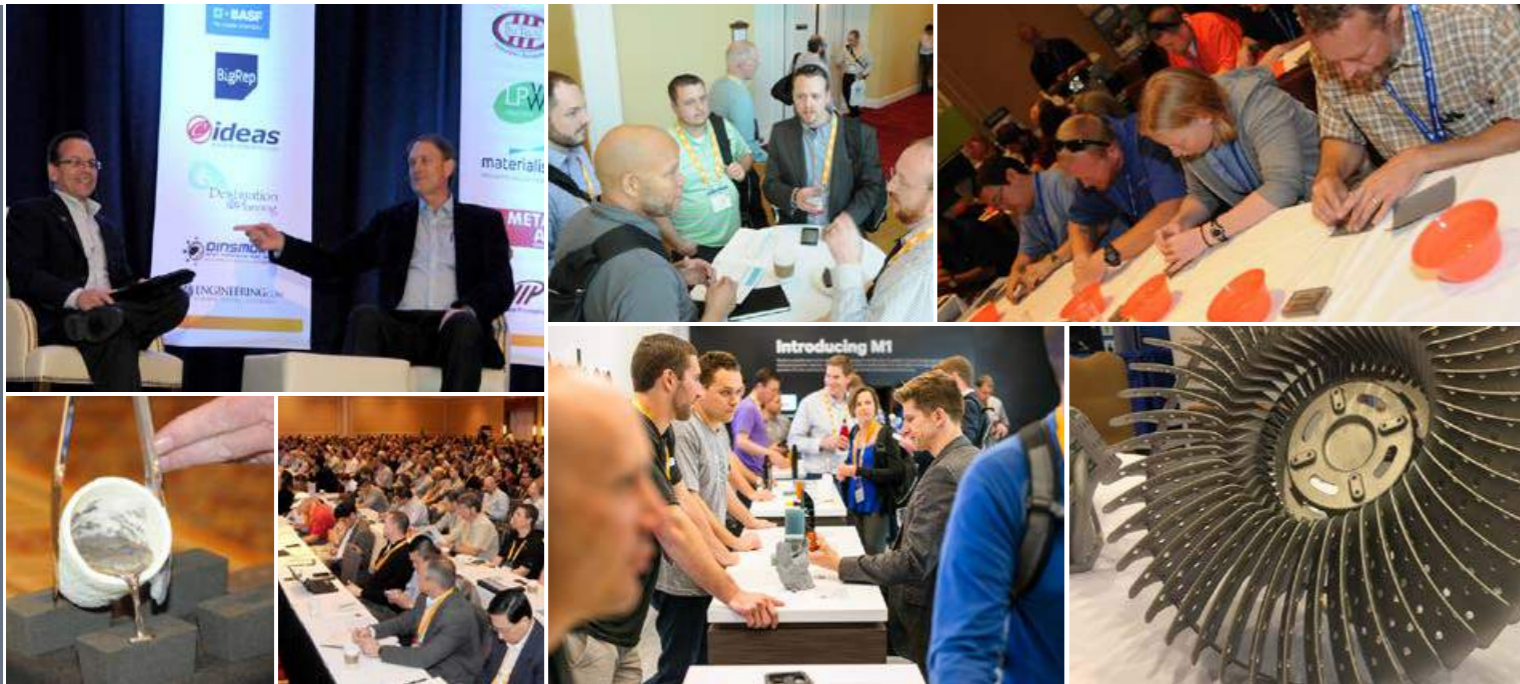

## AMUG For Users, By Users

**Additive Manufacturing Users Group (AMUG) Education and Training Conference** brings together engineers, designers, managers, and educators from around the world to share expertise, best practices, challenges, and application developments in additive manufacturing. The users group is dedicated to the owners and operators of commercial additive manufacturing equipment and those with professional applications of desktop 3D printing technologies. **Join us in 2017!**

### LEARN

In-depth education and training sessions by AM industry experts and OEM representatives.

### NETWORK

AMUG network provides attendees access to users with 25+ years experience in the industry. Attendees network with AM-dedicated OEMs and vendors.

### WHO SHOULD ATTEND

Those that have access to, use, or operate AM equipment:

- > Operators
- > Technicians
- > Managers
- > Engineers
- > Designers
- > Educators

### EXPLORE

AMUG provides access to a variety of metal and plastic technologies:

- > 3D Printing (3DP)
- > Direct Metal Deposition (DMD)
- > Direct Metal Laser Sintering (DMLS)
- > Direct Metal Laser Melting (DMLM)
- > Electron Beam Melting (EBM)
- > Fused Deposition Modeling (FDM)
- > Laser Sintering (LS)
- > MultiJet Modeling (MJM)
- > Multi Jet Printing (MJP)
- > PolyJet
- > Selective Laser Melting (SLM)
- > Selective Laser Sintering (SLS)
- > Stereolithography (SL)
- and many others

**2017 AMUG CONFERENCE**  
March 19-23, 2017  
Hilton Chicago  
Chicago, Illinois

### REGISTRATION INCLUDES

- > Conference (4 days)
- > AMUGexpo (2 nights)
- > Keynote Presentations
- > Innovators Showcase
- > General Sessions
- > Technical Sessions
- > Workshops
- > AMUG Awards Banquet
- > Technical Competition
- > Networking Lunches
- > All Meals and Beverages

**REGISTER TODAY!**  
[www.am-ug.com](http://www.am-ug.com)

For more information on attending, exhibiting or sponsoring, visit the AMUG website: [www.am-ug.com](http://www.am-ug.com)

### 2017 Diamond Sponsors



For a current list of all sponsors visit [www.am-ug.com](http://www.am-ug.com)

# Distortion in metal Additive Manufacturing: Modelling and mitigation

There is a growing recognition that software can play a vital role in determining the success or failure of Additive Manufacturing within an organisation. As Autodesk's Michael Gouge and Pan Michaleris explain, metal AM is about far more than having the right machine or specifying the right material. Dedicated AM software can today quickly and accurately simulate distortion in metal AM processes, significantly reducing build failure rates, minimising the associated economic impact and contributing to the enhancement of the technology's reputation amongst end-users.

Consider this scenario: a company designs a large titanium part for fabrication in a powder bed AM machine. Months are spent rigorously ensuring that the component will meet the required specifications and geometric tolerances. Days are spent preparing the part to be built. The part is so large it takes up the entire build chamber, so it takes days, if not weeks, to finish manufacturing. Then imagine the part cracks during the final hour of building. This scenario is not a hypothetical one, but a story related to us by a customer. Every day we talk to companies trying to use Additive Manufacturing to produce usable parts and each of them talks about the same frustrations: excessive distortion, cracking and recoater blade interference. AM is being sold on the promise that it will make limited production run parts quicker, more efficiently, greener and easier than by using traditional manufacturing methods such as subtractive manufacturing or casting. These promises can only be met after months or years of failed builds produce the expertise within an organisation on

how to predict and mitigate build failure before it happens. Autodesk has acquired a suite of software that packages this expertise together in an intuitive way. The key to avoiding build failure, in particular distortion and recoater blade interference issues, is simulation based mitigation, which is

made possible by Netfabb Simulation. This software forms the centrepiece of an integrated design for manufacturability workflow. This workflow will guide the engineer through the process of designing a part, orienting it on a build plate, optimising the geometry, adding support structures,

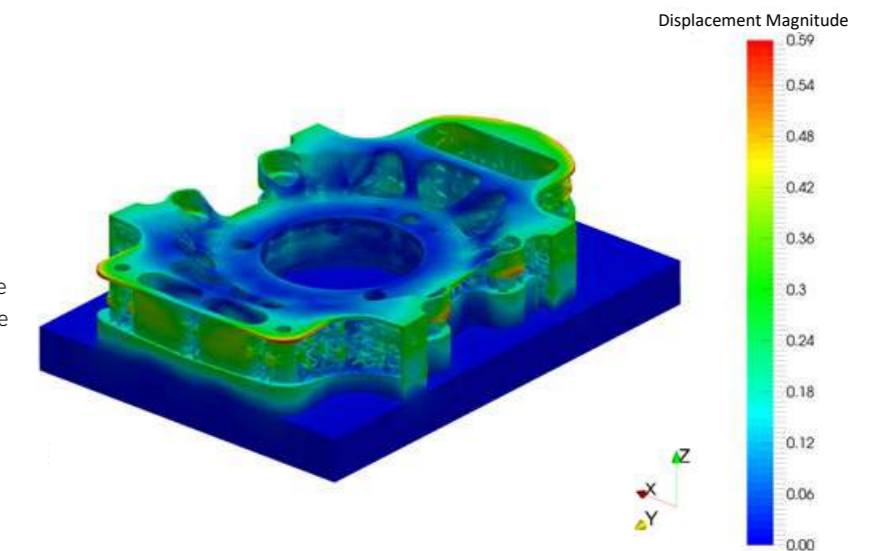

Fig. 1 Sample powder bed fusion simulation part, dimensions are roughly 275 x 200 x 40 mm



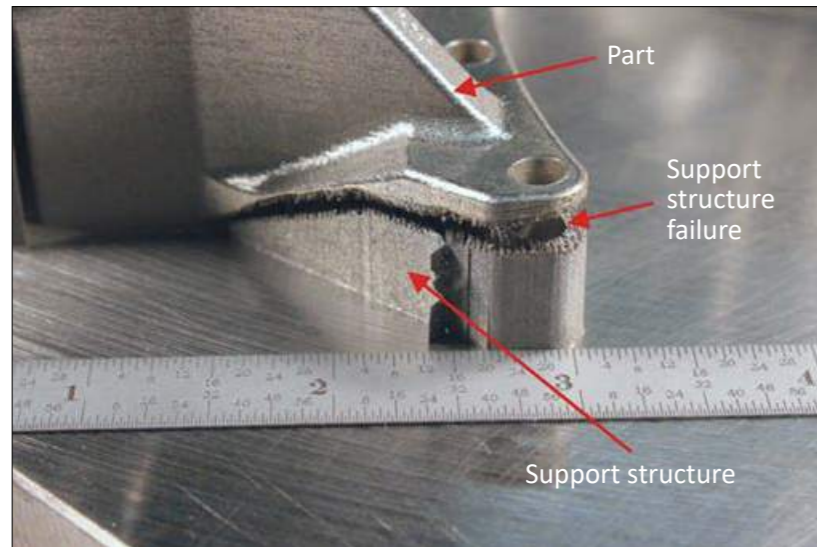

Fig. 2 Distortion example: This part exhibits support structure failure and excessive distortion

predicting and preventing build failure and ensuring the built part will meet end-use specifications. In the 20<sup>th</sup> century a great design engineer would work hand-in-hand with machinists to ensure their vision was feasible. In the 21<sup>st</sup> century, great design engineers will be marked by their success in designing parts that can be economically and repeatedly manufactured.

## The promise of Additive Manufacturing

There is a palpable excitement for Additive Manufacturing, both in the engineering community and the larger world. In the non-technical culture there is a feeling that these machines, transforming a computer generated file into a physical object, are something bordering upon science fiction come to life. For those working in design and manufacturing, these technologies fill very real needs. These needs are: economical small-run production, lowering environmental impacts, improving efficiency and enhancing design capabilities. AM can create real parts, not just prototypes, in a matter of hours. Wasting less material and, in some cases, expending less energy than subtractive processes, AM can help

companies keep their commitments to protecting the environment. With layer-by-layer construction, the popular AM adage 'complexity is free' does ring true. However, often lauded as a panacea for manufacturing and design challenges, the limitations and complications of what is practicable in AM can come home roughly when the first part, which is almost inevitably badly warped or cracked, is pulled from a company's first machine. Engineers quickly learn that distortion during a build is the greatest adversity to overcome before the promise of quick, green and complex part manufacture can be realised.

### The cost of distortion

Distortion in AM has two costs, one economic, one more intangible. The true monetary cost of a failed part is difficult to calculate as it includes not only the consumption of the raw materials and energy to run the machine, but also the time of technicians and engineers who must redesign and attempt to build the improved part again, the opportunity cost of not manufacturing something else during that period and lead time costs for last minute production runs. The intangible cost is the loss of faith. This can be the lost faith of a customer in a service bureau, or organisational loss of faith in AM as a dependable link in the design and

manufacturing chain. Yet distortion during AM is a solvable problem. It requires, however, a deeper understanding of AM processes before the challenge of distortion can be surmounted.

### What causes distortion in AM processes?

Distortion is an unavoidable result of heating a small amount of material to its melting point on an otherwise much colder entity [1]. The material in the heat affected zone (HAZ) naturally undergoes thermal expansion, which temporarily bows the part downward while the top layer is still red hot, as the cooler material is forced to bend to accommodate the expansion of the top. As the material cools, there is thermal contraction at the top of the part as the molten material solidifies, which stretches the lower portions of the component so that it bends upward. The stresses during expansion and contraction are so high that they force the part to yield, which results in permanent deformation.

Distortion is unavoidable, but it can be mitigated. Standard practices to prevent plastic deformation are preheating build plates prior to manufacturing, constantly heating the build plate or build chamber during the manufacturing process, or implementing physical restraints. Preheating and constant heating reduce distortion by decreasing the severity of the thermal gradients which control the extent of the thermal expansion and contraction. While higher temperatures will result in even lower distortion, there are practical limits to what temperatures can be reached [2]. Restraints reduce distortion directly but are limited primarily to reducing build plate distortion in Powder Bed Fusion (PBF) processes. Furthermore, using restraints does not dissipate the bending forces; these forces, instead of causing distortion, result in higher residual stresses. Geometry compensation is the best way forward for improving AM components. Compensation is a way of changing the part geometry anticipating the distortion that will occur during

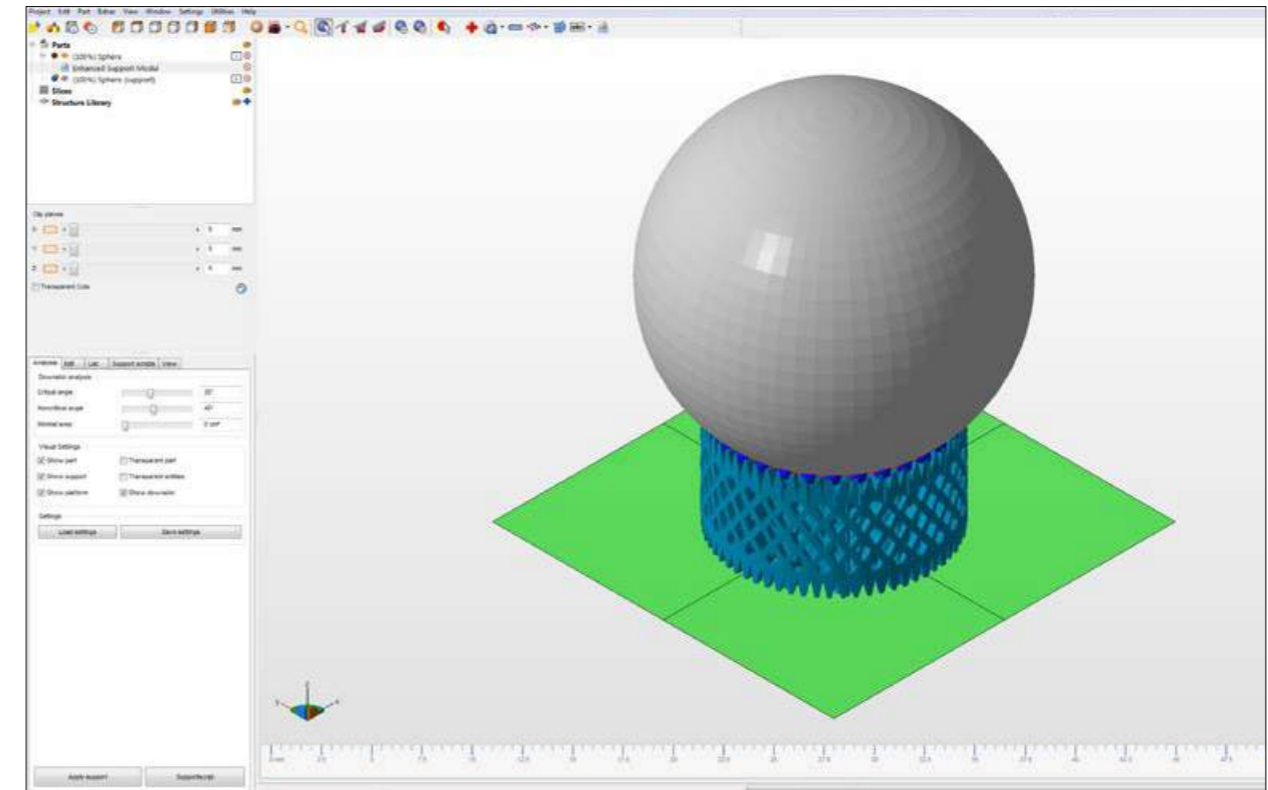

Fig. 3 Adding supports in Netfabb Ultimate

fabrication, so that the part distorts into the desired final shape. Some of our industrial partners are using experimental scans to compensate geometries. This has two drawbacks: it is expensive to build even a single test part and this method only compensates the external faces of a part. Simulation based compensation will obviate both of these problems, so that a predictive model can guide AM engineers to manufacture better parts with a minimum of failed builds. This will be the central point of development for Autodesk's AM suite as it strives to ease and automate the design for AM process.

## Autodesk's commitment to Additive Manufacturing

Autodesk is endeavouring to establish itself as an industrial leader in the AM software marketplace. To this end, Autodesk has pursued strategic acquisitions to build a complete additive software portfolio. The 'grand vision' is to create a seamless suite

of software that encompasses every facet of the design for manufacture process, from CAD to sending the geometry to the AM machine. This will alleviate the many headaches common to piecemeal solutions, including file format conversion, unit errors, inconsistent layout and navigation standards and licensing issues. As the suite becomes fully integrated, with both upstream and downstream compatibility, this will make the iterative design process smoother and quicker, speeding up the time between when the idea for a component is conceived and when a production quality part is pulled from the machine and put to its end use. Currently the core AM suite consists of the following products:

### Netfabb

Netfabb began as a small project at FIT Technology Group which then grew into a fully fledged standalone product. Acquired by Autodesk in September 2015, the Netfabb software provides the tools to perform the intermediary steps between

component design in a traditional CAD package and manufacturing the part. Netfabb is a platform for path planning, aligning parts on a virtual build-plate, adjusting orientation and automatically adding support structures where needed, in addition to a multiplicity of other pre-build functions such as mesh repair and automated part stamping. Netfabb has become the hub for the other pre-build activities such as part optimisation and build distortion modelling and mitigation.

### Within

Acquired by Autodesk in May 2014, Within Labs' software gives design engineers an algorithmic based lattice optimisation tool. Within is used to lightweight components, so only the material required for the specified design performance parameters is used. The lattice optimisation uses Autodesk's Nastran FEA solver to optimise lattices under user controlled static loading conditions. Within, renamed the Optimization Utility for Netfabb,

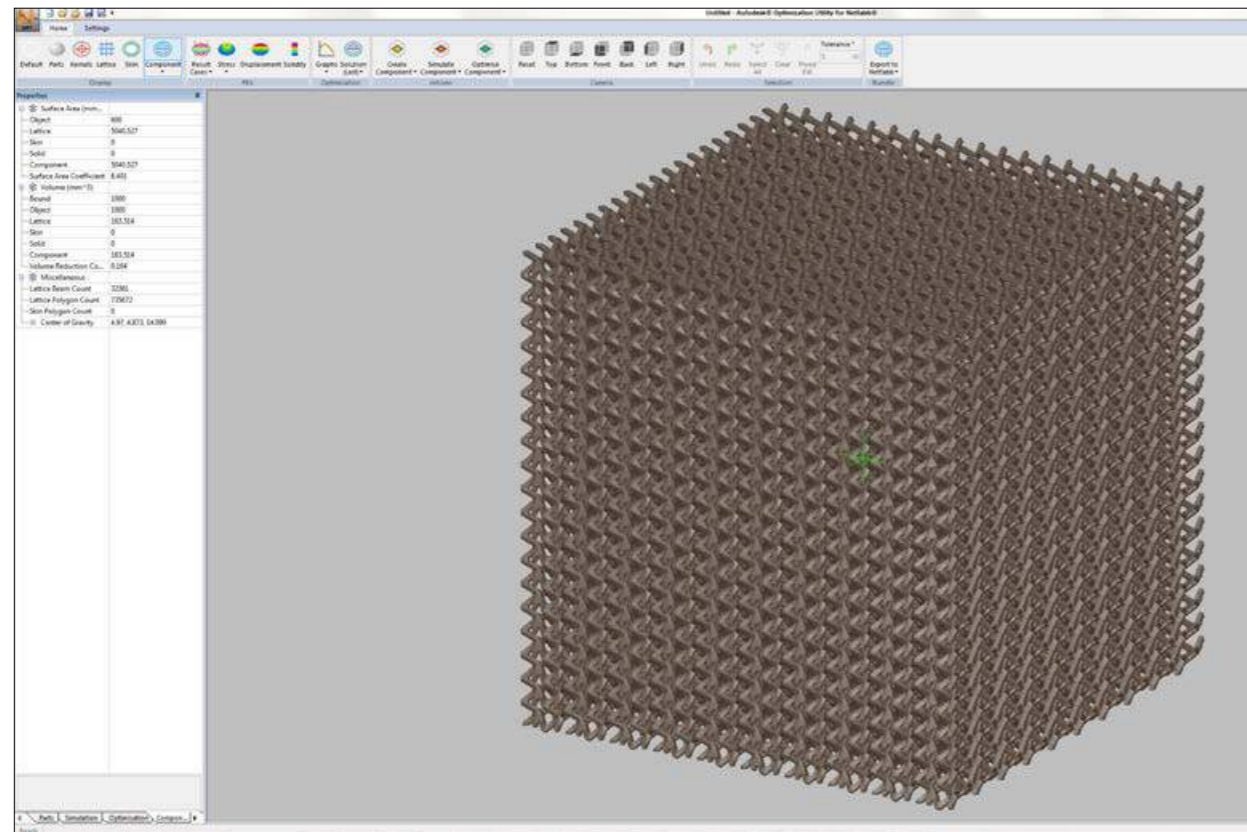

Fig. 4 Latticing a cubic structure using the Optimization Utility for Netfabb

has been integrated into Netfabb, enabling automated latticing of parts in the optimisation tool, then returning the optimised component to Netfabb for final build preparation.

#### Delcam

Already an industry leader in Computer Aided Manufacturing (CAM), Delcam's acquisition in February 2014 by Autodesk expanded the software's potential market penetration, while providing Autodesk a ready-made suite of both subtractive and Additive Manufacturing digital tools. This CAM software portfolio includes Powermill, Powershape, FeatureCAM and Autodesk HSM. Delcam's tooling modelling lets designers plan for post-production build plate removal and additional machining. Delcam has recently partnered with Optomec, makers of the LENS<sup>®</sup> Direct Energy Deposition machines, to provide integrated software for Optomec's new line of hybrid additive-subtractive manufacturing machines.

#### Pan Computing

The acquisition of Pan Computing in March of 2016 significantly strengthened Autodesk's Additive Manufacturing software portfolio. Traditional CAD software, such as Inventor and Fusion 360, enabled component design. Netfabb and Within provided automated tools for pre-production optimisation, support and nesting operations. Pan Computing's software, formerly known as CUBES and now rebranded as Netfabb Simulation, gives Additive Manufacturing specialists the ability to predict and prevent distortion during the manufacturing process. This shortens the design loop for AM. Without rapid and accurate simulations, AM parts go through an expensive and laborious iterative manufacturing cycle. Components are built as designed, then measurements are made of distortion and cracking which informs the part redesign. This process continues usually through five to ten build-redesign cycles until the part can be repeatedly built within the

specified geometric tolerances. Using the simulation tool, our industrial partners have driven down the number of test builds to two to three before attaining an acceptable built component, saving thousands to tens of thousands of dollars per build. With simulation based compensation it is feasible that parts can be built within tolerance the first time.

#### Simulation based AM distortion mitigation

Pan Michaleris found himself in a unique position to make a positive impact upon the nascent field of AM modelling. Michaleris is an established expert in welding modelling, having published definitive works in the area and developing distortion mitigation practices that have become standard in industry [3, 4]. Michaleris cut his programming teeth in the early days of the PC, just as the punch card was being phased out. Learning to code with limited

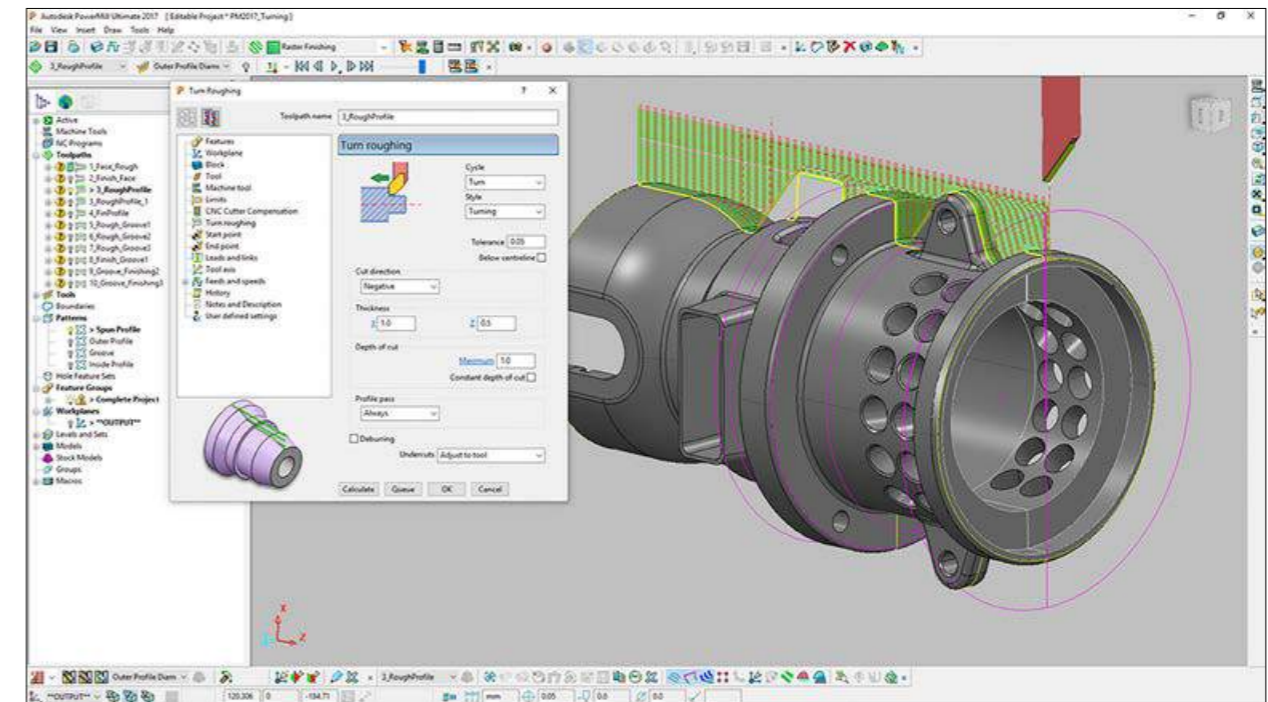

Fig. 5 CAM using Powermill

computational resources instilled upon him a passion for efficiency. In the beginning of this decade Michaleris turned his attention from welding to AM processes. He found that the processes were similar enough that he could immediately apply his expertise to improve AM modelling. In 2012 he co-founded Pan Computing LLC with the view to producing an accurate and rapid physics based thermomechanical model to predict distortion during Additive Manufacturing processes.

Simulating Direct Energy Deposition, or DED, such as the LENS<sup>®</sup> process, was the early focus of Pan Computing. Collaborative efforts with Pennsylvania State University, USA, and Sciaky, Inc., Chicago, USA, helped develop and validate the model for laser and electron beam deposition builds. In return, these institutions used knowledge gained from the simulations to implement new techniques to reduce distortion. From these early successes Pan Computing pivoted to the far more daunting task of modelling of Powder Bed Fusion processes. Powder Bed Fusion allows for manufacturing at a much finer resolution, yielding net

shape parts that require little to no post processing. PBF has come to dominate the market share of AM space, with its promise of creating beautiful, useful parts in a matter of hours. It was this promise, belied by the experience of company after company, with failed part after failed

material properties, capturing the stress and strain behaviour during melting, two-phase and solid-state phase transformations, predicting support structure failure and correctly meshing the often complex geometry of PBF components. While the preceding manifold challenges

*“Pan Computing’s software, formally known as CUBES and now rebranded as Netfabb Simulation, gives AM specialists the ability to predict and prevent distortion during the manufacturing process”*

part, that inspired Pan Computing to develop a tool that was not only accurate, but also fast enough to be useful in industrial practice.

Modelling PBF processes is rife with challenges [5]. These include the addition of material to the model, the application of the heat source, adjusting the boundary losses as the surface evolves, accounting for the temperature dependence of

may seem intimidating, this list is missing perhaps the largest difficulty to overcome, the problem of scale when modelling PBF processes with relation to the finite element mesh.

There are two modelling heuristics that drive the computational requirements of a finite element simulation of an additive process. First, to attain accurate thermomechanical predictions of welding, DED, or PBF,

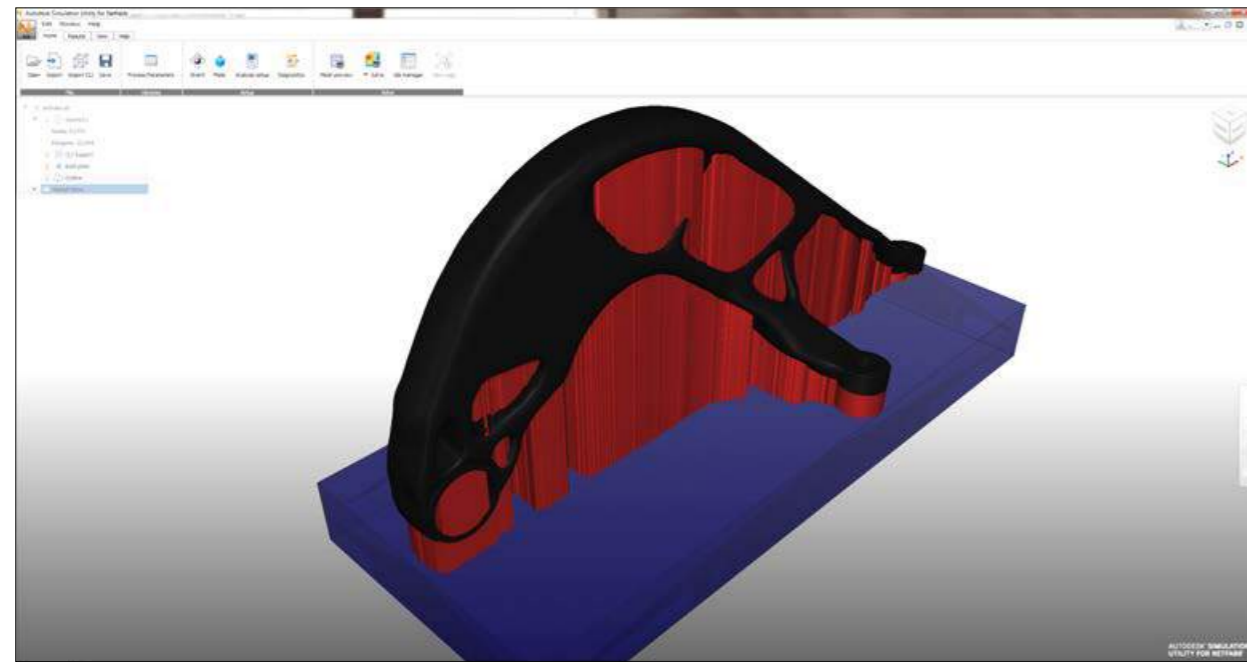

Fig. 6 Simulation Utility for Netfabb: The graphical user interface for the Netfabb Simulation FE solver

the mesh must be sized small enough to capture the melt pool region. Secondly, the discrete time steps taken must be short enough not to induce aliasing. The challenge when moving from DED to PBF modelling hinges upon the fact that the former has melt pools about 1-2 mm across and typically occurring at a rate from 10-25 mm/s, while the latter have melt pools about 0.05-0.2 mm across and melt material at a rate of 500-1000 mm/s. These two require-

ments make the traditional, direct method of simulation impossible for industrial processes, as they would take hundreds of terrabytes of memory and years to compute.

These excessive computational demands have motivated the multi-scale modelling approach. Multi-scale modelling breaks the problem into two. A small scale simulation that models the heat source captures the physics directly. Then a part scale simulation

maps results from the small scale simulation to the actual build geometry. This process facilitates the prediction of distortion for large and complex structures in a useful time frame. On a robust workstation an entire simulation, from small scale to part scale can be completed in a few hours for simple parts and within a day for even the largest, most complex parts attempted using the software.

#### Detailed small-scale process parameter model

Input: Process parameters (Power, scan speed, layer, thickness, etc.)

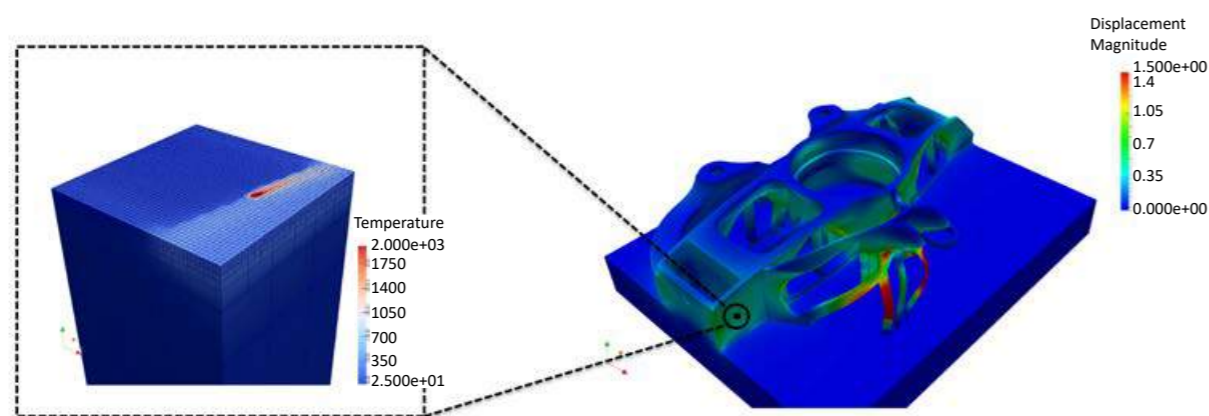

Fig. 7 The multiscale method

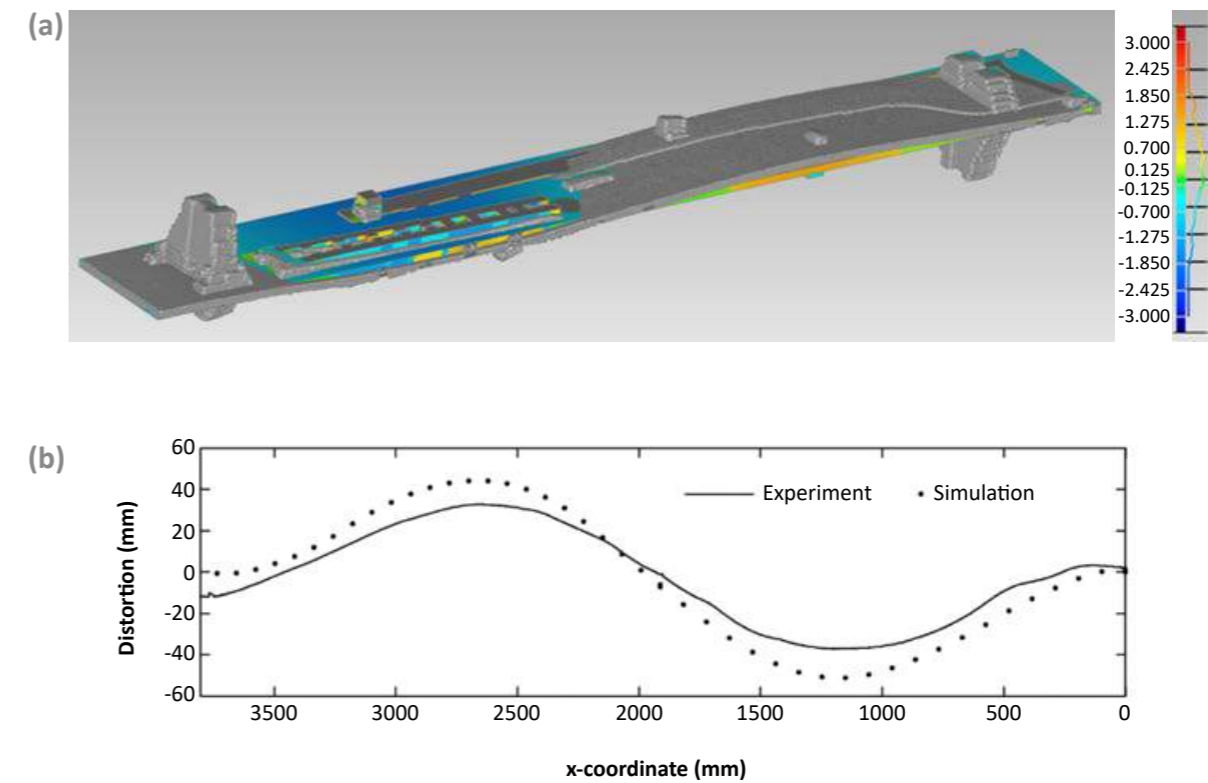

Fig. 8 DED validation study: (a) Sciaky test geometry, (b) simulated vs. experimental distortion of the DED test geometry

#### Distortion model validation

The modelling tool was shown to be fast but its accuracy remained to be proven. Through a series of partnerships with public and private entities the simulation tool has been validated for the most popular AM alloys and these efforts are detailed below.

#### Direct Energy Deposition modelling

The largest part that we have ever simulated is a test part made by Sciaky, shown in Fig. 8(a) [6]. The base plate was roughly 4.3 m long x 0.5 m wide [14 ft x 18 in.], upon which several kilograms of material was deposited. The deposition was performed using electron beam direct energy deposition. 3D scans were taken of the finished part, but held back by Sciaky until the simulation results were delivered. The simulations were completed using the direct modelling approach, which took around 24 hours to

complete on a 16 core machine. The numerical comparison of the measured distortion is presented in Fig. 8(b), which shows the simulation nearly perfectly captures measured distortion. A subsequent modelling study developed a simple distortion mitigation technique that Sciaky later employed to useful effect [7].

#### Multi-scale modelling of Laser Powder Bed Fusion processes

CIMP-3D, The Center for Innovative Materials Processing through Direct Digital Deposition at Penn State was one of the closest collaborators with Pan Computing and continues to be so with the Autodesk Netfabb Simulation team. A recent project headed by Ted Reuxel and Alexander Dunbar involved the modelling of a compliant component they designed, the flexible cylinder shown in Fig. 9(a). The cylinder was built at CIMP-3D on a 3D Systems ProX320 out of Inconel 625, then 3D scanned. A plot

of both the measured and modelled distortion along one face of the cylinder is presented in Fig. 9(b). This shows excellent agreement between the model and the built part.

This is but one of numerous validation cases for the modelling of distortion in PBF processes. We have validated the model for Inconel 625, Inconel 718, Inconel 718 Plus, Ti-6Al-4V and AISi10Mg with builds from GE Global Research Center (GEGRC), United Technologies Research Center (UTRC), Honeywell, Moog and other industrial partners.

While the accurate and rapid prediction of part-scale PBF distortion is the primary use of Netfabb Simulation, there are additional features of the modelling software. These include predicting support structure failure and warning the user if recoater blade interference is likely, along with several other model improvements underway.

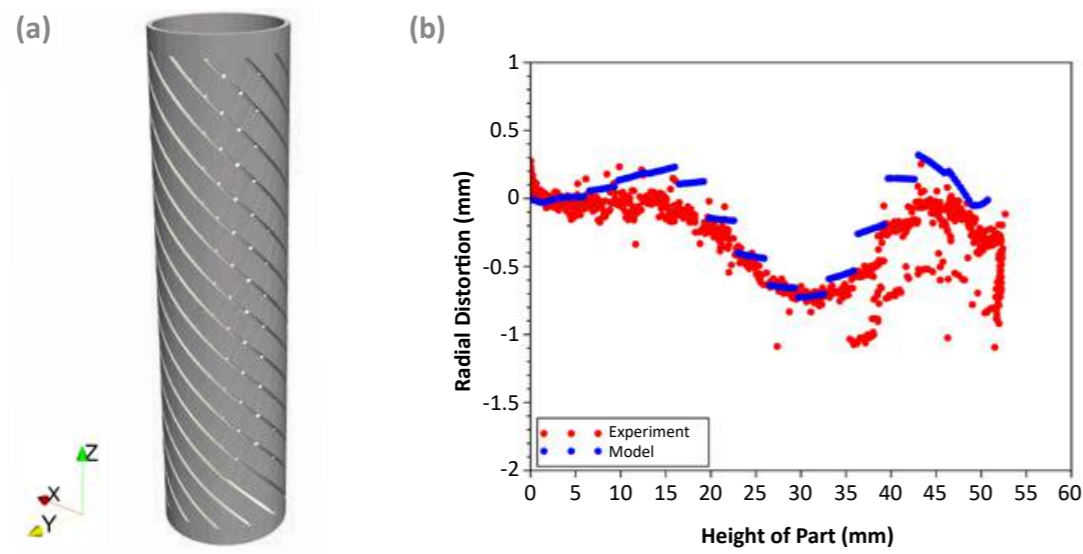

Fig. 9 PBF validation study: (a) compliant cylinder geometry, (b) simulated vs experimental distortion of the PBF cylinder [Courtesy CIMP-3D]

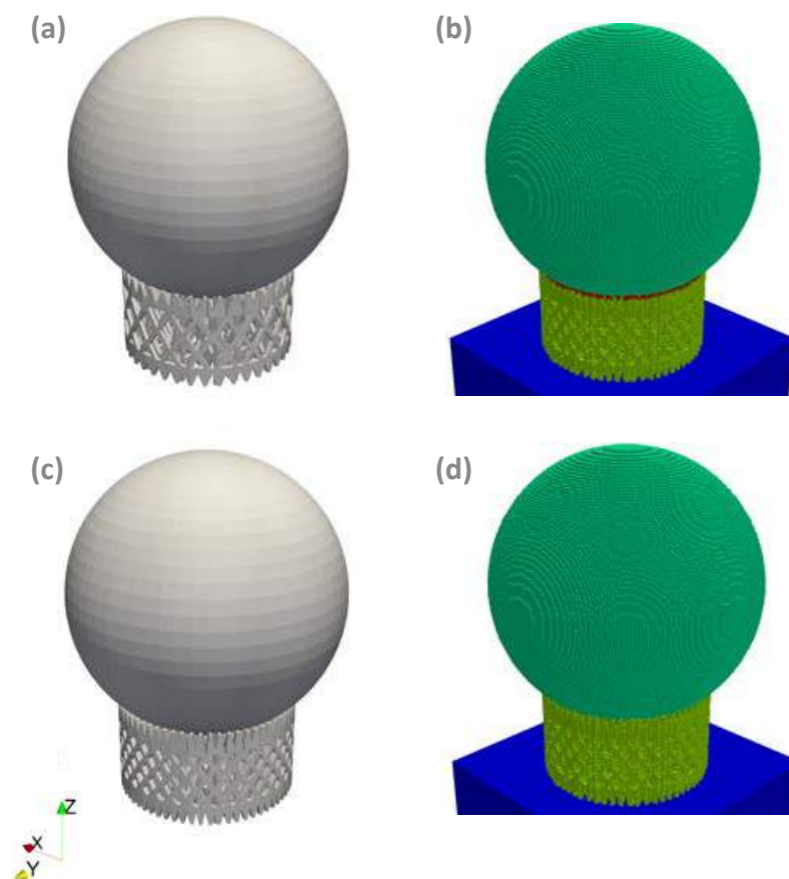

Fig. 10 Support structures: (a) typical support structure with latticing and teeth connections, (b) modelled support structure failure, red indicates failed support, (c) strengthened support structures, (d) modelled strengthened support structure failure

### Support structure failure and model based support optimisation

Support structures are the principal tool design engineers and additive technicians have to control distortion in AM processes. The term support structure is somewhat misleading, as the action and purpose of these components is to hold the part down, and not up. This is due to the upwards deflection described previously, so they are employed to anchor parts to the build plate [8]. As this is sacrificial material, supports are generally built much less densely than the component, so these typically are thin walled structures, frequently latticed to further diminish their density and with teeth like connections which ease their removal, as shown in Fig. 10(a). All of these reductions in cross sectional area increase stresses applied to supports during manufacture. These stresses can often exceed the support structure's tensile strength, resulting in failure. This can lead to the excessive distortion the supports that were put in place to prevent, and in the worst cases lead to, recoater blade interference. This issue is described more in detail later.

Netfabb Simulation has implemented support structure failure prediction to help improve the reliability of PBF builds. Support structures may be modelled directly or homogenised to coarsen the elements to speed up simulation times. Support failure is indicated visually in the results, as shown in Fig. 10(b). Inspection of the failure region and geometry lets AM engineers thicken up the anchoring structures just in the region of concern, as illustrated in Fig. 10(c). The strengthened supports experience a significant reduction in failure, as shown in Fig. 10(d). Using simulation based optimised supports will produce a better physical part once built. Alternatively, overly bulky structures may be iteratively reduced to minimise material costs via the same methodology. Using the modelling software support structure failure prediction prior to attempting building can be used to reduce excessive distortion or material wastage, improving the economic feasibility of AM practice.

### Recoater blade interference

Recoater blade interference is the most destructive and expensive form of failure in PBF processes. This occurs when the upward distortion is so excessive that the top of the build component juts above height of the top of the next powder layer. When the powder is being spread back over the build chamber, the powder spreading device, called the recoater, will collide with the component. Some machine manufacturers have designed their recoating device to be out of a compliant material, such as a polymer or elastomer. These will experience minimal to no damage upon contact with the component, but the integrity of the build geometry will be reduced as there will be a portion of the build surface with one or more incomplete powder layers. Many manufacturers still use metal recoater blades and when these impact the component the failure can be catastrophic. The recoater will likely damage the part and in turn the part will bend and warp the recoater

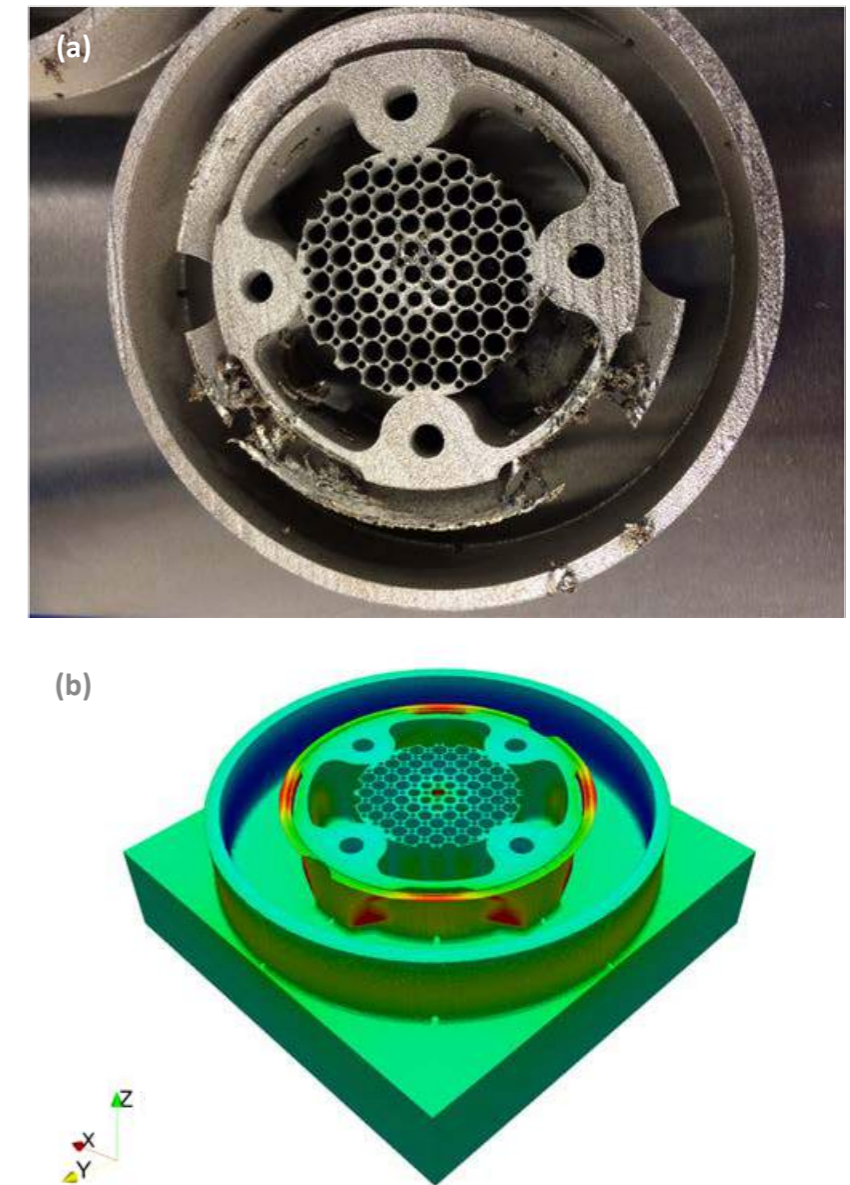

Fig. 11 Recoater interference study: (a) part damaged by recoater blade impact, (b) modelled distortion at the height of recoater impact [Courtesy Tim Simpson and CIMP-3D]

blade. This means the machine will have to be repaired, the recoater replaced and the component rebuilt from the beginning. Recoater blade interference is predicted by Netfabb Simulation as an extension of its distortion modelling. During the part level build simulation the code checks if the vertical displacement is large enough to warrant concern about recoater collisions. The user will be issued a warning if the upwards distortion is extreme enough to cause an recoater

collision incident. This method has been experimentally validated due to the misfortune of one of our customers, evidenced in Fig. 11. Modelling was performed *a posteriori* of a part that was known to experience recoater blade interference. Fig. 11(a) clearly shows the damage caused by the recoater-part collision. The model predicts excessive vertical deflection at the same height and planar location, as shown in Fig. 11(b). This validates the ability of the model to warn users

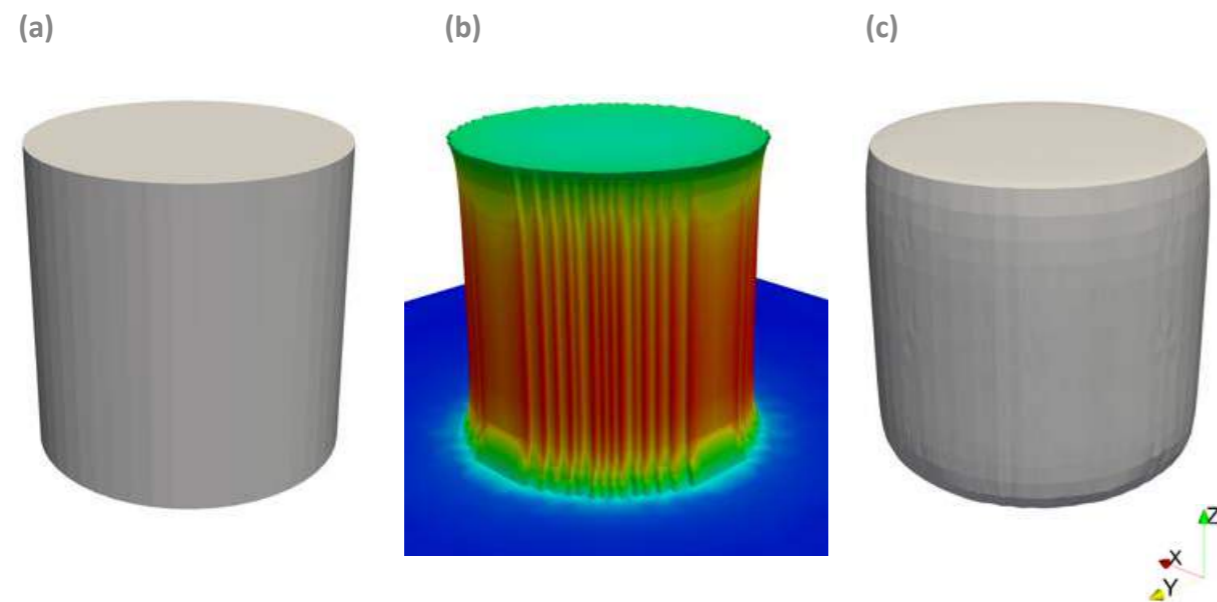

Fig. 12 Sample compensation: (a) desired final geometry, (b) modelled distortion

about potential recoater issues. This predictive tool enables engineers to redesign, reorient and add support structure components to eliminate the threat of recoater blade interference.

### Simulation based geometry compensation

Producing a geometry that can be manufactured free of distortion the first time around is the ultimate goal for any AM simulation software. Current users in industry report that using the simulation tool they are able to bring the number of builds before obtaining a usable component from five to ten to perhaps two or three. Geometric compensation, where a part is altered based upon the measured or simulated distortion so it warps into place, as depicted in Fig. 12, has been hypothesised as the silver bullet for eliminating unwanted distortion. This would drive the builds required to produce a usable part from a new geometry down to one and would be a threshold achievement for the AM industry. Simulation based compensation would eliminate one of the biggest recurring costs to designing a part

for metal AM construction, the thousands or tens of thousands of dollars spent perfecting the geometry through trial and error. With a compensation tool, parts that would have been economically unsound to manufacture become feasible. Businesses would recoup their AM investments in a much shorter time frame and industrial adoption would accelerate. This in turn would trigger economies of scale, which will bring AM out of its current niche research and development state to become as standard and unremarkable a part of a manufacturing chain as the end-mill.

Netfabb Simulation has a model based compensation tool currently in testing. Compensated geometries have been manufactured from simulation results by several of our industrial partners as part of both ongoing research and for real world applications.

### Future outlook

Both Additive Manufacturing and the simulation of additive processes are in their nascency. Practices and technology are still in development and in flux and each year machine

manufacturers are able to produce parts with finer resolution and in shorter times. Netfabb Simulation, though in a class by itself as a truly predictive software for AM distortion prediction, failure mitigation and optimisation, has plenty of room to improve and expand its capabilities. In the near term this includes the addition of validated materials, prediction of stresses and cracking and post-build heat treatment.

### Expanded material support

Currently Netfabb Simulation has been validated for Inconel 625, Inconel 718, Inconel 718 Plus, Ti-6Al-4V, CoCr and AlSi10Mg. Autodesk has agreements with multiple organisations to build validation test plates for the addition of cobalt chrome, 316L, 17-4 PH and 15-5 PH stainless steels and AISI 4340 low alloy steel modelling capabilities. This plan will be executed in the first half of 2017.

### Crack prediction

Some common AM materials, particularly titanium alloys, are quite susceptible to cracking during PBF. This is a current focus of the Netfabb Simulation research team. Efforts are being made to apply traditional fracture mechanics methods, with

crack initiation and crack propagation models, to the build process simulation. Crack modelling may require refinements in stress prediction methods and addition of measurements of material toughness to the list of material properties needed to complete the simulation.

### Heat treatment modelling

Common heat treating processes for additive parts are stress relaxation, annealing, quenching, and Hot Isostatic Pressing (HIP). These are used to remove residual stresses, homogenise and refine the microstructure and reduce porosity. These thermal processes may cause additional distortion or even cracking in the part. Modelling post processing will allow AM engineers to predict and mitigate undesirable behaviour using these techniques while also giving practitioners guidance for implementing them.

### Further integration of Autodesk AM software tools

The Netfabb bundle is CAD agnostic, with over 40 supported file types users can create their geometry in almost any CAD tool and use it within the preparation-optimisation-distortion prediction suite. Yet it would further ease the wall-less design if Autodesk's engineering oriented CAD packages, Inventor and Fusion 360, could export parts designed for powder bed construction directly to the Netfabb bundle.

At the other end of the design process, it would be similarly advantageous to be able to feed the simulated, warped geometry into Nastran, Autodesk's general purpose FE package. Then the user could ensure that not only would the as built part meet its geometric requirements, it could also be tested to ensure it upholds its design through analysis of its performance with regards to heat transfer, failure, fatigue, etc.

Finally, work has already begun integrating both Netfabb Optimization and Netfabb Simulation with Dreamcatcher. Dreamcatcher is a general purpose optimisation software that can provide detailed analysis,

machine based design and material suggestions. Using this optimisation software could further guide or even automate component design for additively manufactured parts.

### Conclusions

Excessive distortion during the build process is the largest impediment for AM technologies to become economically feasible and widely implemented in everyday manufacturing practice. Netfabb Simulation offers the predictive capabilities to reduce distortion, along with the related phenomena, support structure failure and recoater blade interference. This simulation tool has been thoroughly validated for both DED and PBF processes. Modelling can then guide distortion mitigation efforts to reduce the number of build failures for a new geometry.

Using simulation based compensated geometries automates the design for manufacturability process, further reducing, or altogether eliminating distortion driven build failures. The near term future improvements, validating additional materials, implementing crack prediction and extending the model to heat treatment processes, will result in an even more robust predictive tool that will reduce wastage and accelerate the adoption of AM at the industrial scale.

### Author

Michael Gouge and Pan Michaleris  
Autodesk Inc.  
200 Innovation BLVD  
Suite 208  
State College, PA 16803  
USA

Tel.: +1 814 954 7109  
Email: michael.gouge@autodesk.com,  
pan.michaleris@autodesk.com  
www.netfabb.com/capabilities/  
simulation

### References

- [1] Erik R Denlinger, Jarred C Heigel, Pan Michaleris and TA Palmer. Effect of inter-layer dwell time on distortion and residual stress in Additive Manufacturing of titanium and nickel alloys *Journal of Materials Processing Technology*, 215:123–131, 2015.
- [2] M Shiomi, K Osakada, K Nakamura, T Yamashita, and F Abe. Residual stress within metallic model made by selective laser melting process. *CIRP Annals-Manufacturing Technology*, 53(1):195–198, 2004.
- [3] Panagiotis Michaleris and Andrew DeBiccari. Prediction of welding distortion. *Welding Journal-Including Welding Research Supplement*, 76(4):172s, 1997.
- [4] P Michaleris, J Dantzig, and D Tortorelli. Minimization of welding residual stress and distortion in large structures. *Welding Journal-New York*, 78:361–s, 1999.
- [5] Panagiotis Michaleris. Modelling metal deposition in heat transfer analyses of additive manufacturing processes. *Finite Elements in Analysis and Design*, 86:51–60, 2014.
- [6] Erik R Denlinger, Jeff Irwin, and Pan Michaleris. Thermomechanical Modelling of additive manufacturing large parts. *Journal of Manufacturing Science and Engineering*, 136(6):061007, 2014.
- [7] Erik R Denlinger and Pan Michaleris. Mitigation of distortion in large additive manufacturing parts. *Proceedings of the Institution of Mechanical Engineers, Part B: Journal of Engineering Manufacture*, page 0954405415578580, 2015.
- [8] Wei Gao, Yunbo Zhang, Devarajan Ramanujan, Karthik Ramani, Yong Chen, Christopher B Williams, Charlie CL Wang, Yung C Shin, Song Zhang, and Pablo D Zavattieri. The status, challenges, and future of additive manufacturing in engineering. *Computer-Aided Design*, 69:65–89, 2015.

# Trends. Analysis. Forecasts.

Your source for everything 3D printing

**NEW**



## Wohlers Report 2017

3D Printing and Additive Manufacturing State of the Industry  
Annual Worldwide Progress Report

**WOHLERS**  
ASSOCIATES

**Order your report today!**

**WOHLERS**  
ASSOCIATES

wohlersassociates.com

- Undisputed industry-leading report for 22 consecutive years
- Estimates and forecasts based on years of hard data
- Input and analysis from the largest group of experts worldwide

## Materialise Magics: Advanced part orientation and support solutions to speed up application development

Materialise NV, headquartered in Leuven, Belgium, has more than 25 years of experience in developing industry-leading software for Additive Manufacturing. The company also operates some of the largest AM factories in Europe, including a metal AM facility in Bremen, Germany. Kirsten Van Praet reveals how the latest release of the company's Materialise Magics suite can help users achieve higher levels of AM production success through advanced part orientation and support solutions. Key advantages of the metal AM process are also reviewed through a case study and a number of application examples.

Choosing the right manufacturing technique for a given application usually holds very few secrets and comes naturally to most designers and engineers. For decades, they have had a palette of well-known metal manufacturing methods at their disposal: machining, casting, moulding, welding, extrusion - every single one with its own strengths and weaknesses. Knowing when to choose a growing technology such as metal Additive Manufacturing is far more challenging and raises both questions and uncertainty.

In order to fully benefit from the opportunities presented by Additive Manufacturing, it is therefore necessary to begin with a thorough understanding of the technology, the materials and the design process. A successful metal AM part is always the result of an effective interplay between these factors in relation to the application. Some applications will benefit more from the opportunities than others, resulting in significant improvements in terms of weight, performance, functionality and/or aesthetics.

In general, the main benefits of metal Additive Manufacturing are design freedom, production speed and cost reduction. In conventional manufacturing, a product's functionalities and appearance are a direct consequence of the manufacturing process of choice.

Additive Manufacturing, however, by means of its layer-wise production, suffers from almost no manufacturing boundaries, especially in terms of geometrical freedom. This results in new and exciting opportunities for product design.



Fig. 1 Metal Additive Manufacturing at Materialise's Bremen production facility



Fig. 2 This aluminium flow cooler with complex internal channels (see inset image) effectively demonstrates the unique design capabilities of the Additive Manufacturing process

The volume-based cost calculation of a part, as opposed to a complexity-based one, motivates designers and engineers to actively and economically explore more complex shapes, working towards an optimal functional design (Fig. 2).

Unlike conventional production methods, Additive Manufacturing requires no additional tooling during the production process. As a result, start-up time and costs are limited and independent of the batch size or the number of design variations of one part. This means stock levels can be kept low and necessary design changes can be implemented quickly. This speeds up and optimises the product development cycle and opens doors for customisation and on-demand production. It also allows a reduction in terms of components of the part, which means some assembly steps, such as welding or bolting, are no longer needed. This may also offer additional advantages in relation to component integrity and lifetime.

### How software can contribute to process stability

The Additive Manufacturing of metal parts can be challenging. Today's market defines the initial learning curve as a two-year period characterised by trial and error experiments, build crashes, vapourised money and time, all mixed in with the occasional correct build. A thorough understanding of how the metal Additive Manufacturing process works is therefore essential.

Whilst it is critical to understand and consider the whole manufacturing process, from powder characteristics to design guidelines and process parameters, including post-processing steps, some of the main stumbling blocks linked to metal Additive Manufacturing are thermal stresses, deformation and shrinkage. How a design engineer positions a part and generates support structures has a huge influence on the success of a build.

Software therefore plays a key role in the metal Additive Manufacturing

process. Materialise's Magics software, core of the company's flexible software suite, is based on an in-depth understanding of the mechanisms behind metal AM, guiding the user on the issues such as best part orientation and support generation. A number of advanced build validation tools analyse the build risks of a part and its support structures to help detect and avoid issues.

### Part orientation

A good part orientation is the first step to a successful build, barring warping or a premature termination of the build process. Users can prevent warping by limiting the surface area of each layer and thereby controlling heat build-up. Large differences in temperature between two consecutive layers compromise build quality and can lead to build crashes, so users need a tool that allows them to analyse the surface area for each layer along with the heat distribution within a build.

One of the new tools in Materialise Magics<sup>21</sup> is the slice distribution

graph tailored for metal applications, which gives users total control of the build process (Fig. 3). With the slice distribution graph, users can quickly visualise the surface area per slice to improve part and build quality. This can be done for one or more selected parts or for the entire build platform. The tool also takes into account support structures.

For metal Additive Manufacturing production machinery that is equipped with more than one laser, a multi-optics option ensures an evenly distributed workload. Users can adjust the orientation of parts or position them in different areas of the build platform and all data can be exported to Excel for a more detailed analysis of the results, helping to achieve an optimal part orientation.

The Magics orientation tools help users orient parts intelligently. This can lead to a reduction of support structures, decreasing material usage and reducing post-processing work. With the Orientation Optimizer tool, for example, users can mark the zones of the part where they do not want to have any support structures. They are then guided to an orientation in which the zones are self-supporting. The Automatic Placement tool makes it easier to position parts by doing some of the work for you.

Depending on the user's goal, optimal orientation could consist of the right balance between the reduced surface area per layer and the amount of support needed. The support preview tool gives users a preview of how the support structures might look once generated. The preview is updated in real time during the orientation, cutting down the number of orientation iterations.

### Support generation and function

In metal Additive Manufacturing, support structures fulfil a greater purpose than simply supporting a part during the build process. Optimal support generation minimises deformation, prevents build crashes and reduces post-processing work.

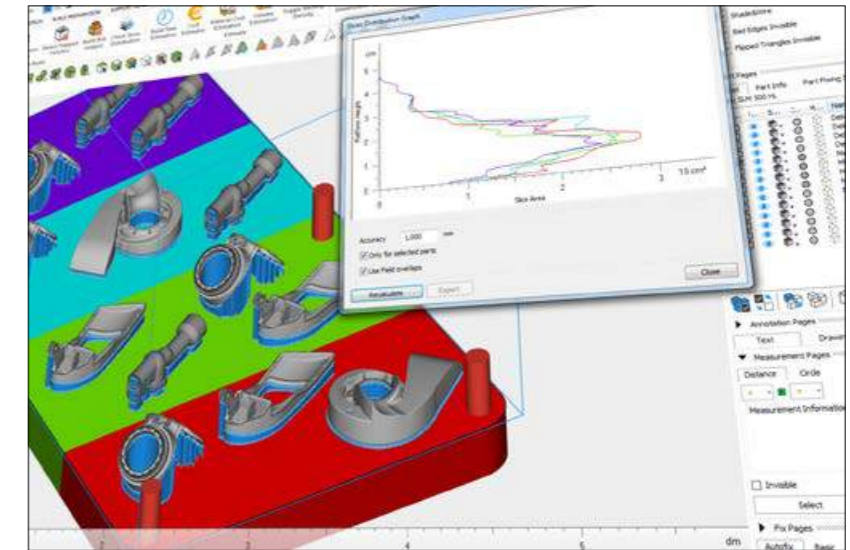

Fig. 3 Screen shot of the slice distribution graph in Magics<sup>21</sup>

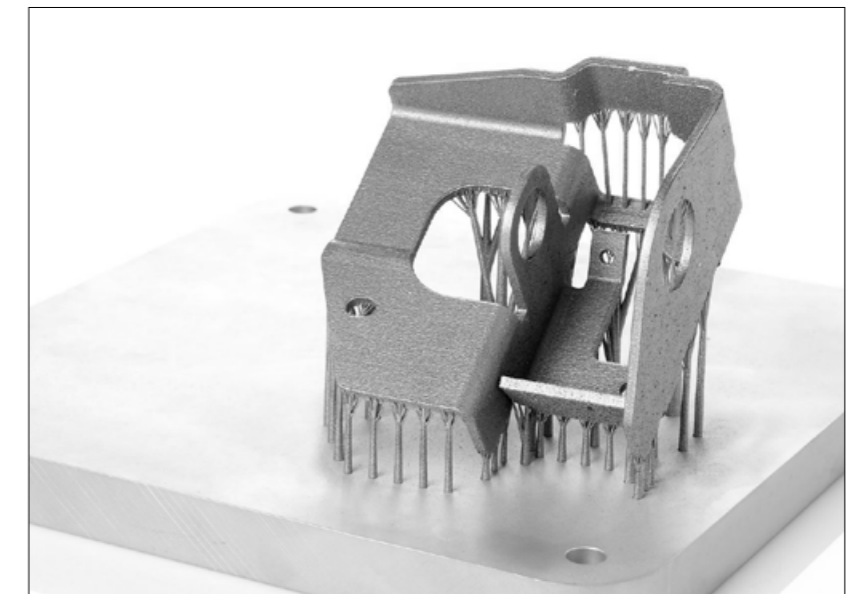

Fig. 4 An example of the use of tree support structures

There is a wide range of support types, each with its own unique benefits. Depending on the geometry of your part, a specific selection will lead to the best results. For instance, cones and tree supports are particularly interesting for small, thin parts and jewellery (Fig. 4). Materialise Magics provides support structures within a semi-automatic process. Users can set custom parameter profiles and easily tweak them afterwards when needed. They can also create their own support structures in CAD and then import them into Materialise Magics.

### Manage heat and avoid deformation

To more effectively conduct the heat from the part to the build platform, Magics allows the use of volumetric support elements. These elements also make sure deformation is avoided by anchoring the part firmly to the build plate. With the software library, users can thicken specific supports as well as choose between solid volume, blocks, cones, tree support structures and more.

Block support structures look like a grid of lines, with each line normally assuming the thickness of the melt pool. With a new feature in

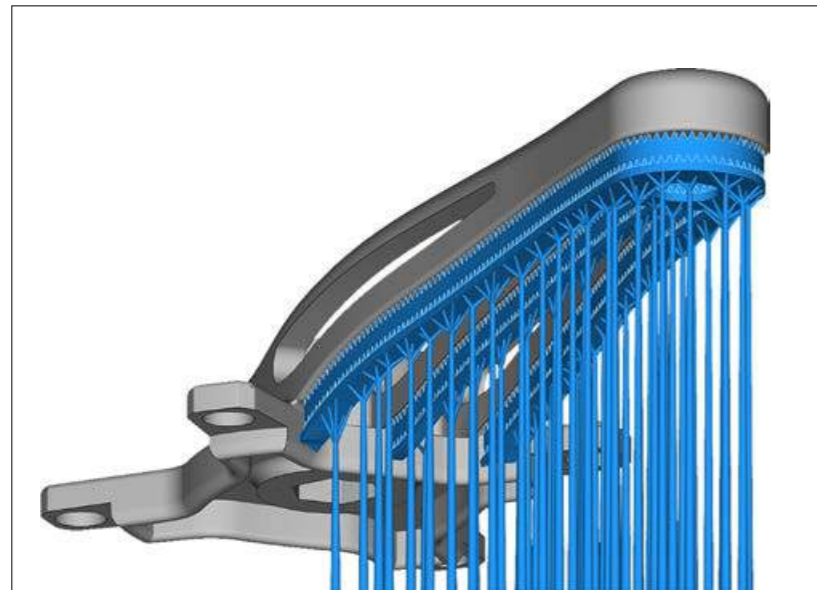

Fig. 5 A brand new type of support in Magics<sup>21</sup> is the patented hybrid support structure



Fig. 6 This hydraulic valve by VTT and Nurmi Cylinders was anchored with angled support structures

Magics<sup>21</sup>, you can thicken the borders of the grid to conduct the heat more effectively and avoid warping.

#### Strategies for improving part stability

A powder-bed machine's recoater system can have a significant impact on the part and its support structure during the build process, which might result in the part shifting. In addition, a deformed part's edges

may protrude over the powder bed, which can potentially lead to a collision that could damage the part and/or the recoater mechanism. A strong connection to the platform is therefore imperative.

With the rescaled platform projection area tool, users can expand support structures and strengthen the connection with the platform. The teeth size, shape, penetration level and other parameters also

influence the strength of the support structures. For instance, a cylindrical platform connection can reduce build failures by offering a stronger connection to the build platform.

#### Saving material with patented hybrid support structures

A brand-new type of support in Magics<sup>21</sup> is the patented hybrid support structure. This support structure is particularly useful when a certain height from the build plate is needed. It consists of three different parts: the upper part is block support, the middle part is volume support and the lower part consists of tree or cone support structures (Fig. 5).

Metal support structures have to fulfil somewhat conflicting requirements. On the one hand, they need to counteract the stresses generated in the metal AM process and hold the part in place, whilst, on the other hand, they remove the heat generated by the process as excess local temperatures may lead to poor surface quality and/or poor mechanical properties.

To hold the part in place and counteract stress, a user would ideally use bulky, volume-type support structures (trees/cones/solid STLs) placed in well-chosen positions. Such support structures are strong, quite easy to remove, fast to scan and do not trap powder inside. To achieve parts with good surface quality, however, it is crucial that abundant contact points with the part are present, as for example with block supports. This ensures proper, local heat conduction, avoids dross formation and yields good surface quality.

Hybrid support structures allow users to benefit from the best of both worlds. At the top, there are block support structures to obtain the surface quality that is required; at the bottom, far away from the functional part, there are solid support types (trees/cones) that are fast to manufacture, consist typically of less material (smaller total volume) and do not trap unmelted powder within them. Choosing cones offers more stability, whereas tree support

structures really limit powder usage. The middle plate ensures good heat transfer from the block support to the tree/cone support structures.

Users can tweak the parameters of the block support structures: they can adjust the thickness, make the teeth larger or smaller and perforate the structure or fragment it. Users can also select a specific hatching style. Next, they can choose the thickness of the middle plate. Finally, the user can tweak the tree or cone support structures. The distance between the cones/trees can also be controlled and their thicknesses adjusted. When using tree supports, users can also select the number of branches per trunk.

A great advantage of hybrid support structures is that the placement is fully automatic, saving a significant amount of time. If a user had to generate such a combination of support types themselves, it would take hours if not days. In addition, this type of support reduces the scanning time as well as the effective volume of the printed support structures. Hybrid support structures therefore lead to improved surface quality, reduced material usage and a reduced process time.

#### Support removal considerations

In cases where support structures have to be removed manually, easy support removal and smart support placement technology can significantly reduce finishing time.

#### Smart support placement

If support structures normally touch a part in two different areas, for instance inside a tube, users can work with angled support structures. With these structures, a user can manually guide the support structures from their part to the build platform, avoiding unnecessary contact points (Fig. 6). If the connection with an area of a part cannot be avoided, the user can guide the support structures to an area that is easier to process such as a flat surface rather than



Fig. 7 This automotive part is supported by block support structures. Block support, as opposed to volumetric support, is not completely solid

a curved one. With the rescaled platform projection tool, users can also downsize the width of support structures to limit the area that requires post-processing.

#### Easy support removal

Solid support structures can be combined with fine teeth that are strong but easy to remove, or they can select predefined break-off points. The latter have the form of an hour glass and will break off in the middle. This avoids the pitting that can result from poor support removal and damaging the part. The user can then smoothen the surface. Fragmented block supports or a clearance between the support structures also facilitate support removal.

Another way to remove support structures without compromising surface quality is by adding some additional material at the places that need the support structures. These can then be milled to obtain the intended final shape, a feature in Magics<sup>21</sup> called milling offset.

#### Recuperating valuable powder

As AM grade metal powder can be very expensive it is preferable to recycle as much of the powder as possible. For safety and contamination reasons it is also

best to remove as much powder as possible in a controlled atmosphere before removing the support. With perforations and fragmentations of surface support, Magics can ensure the recuperation of powder while preserving the strength of supports. Designers can also hollow solid supports or place a structure inside them to reduce build time.

#### Optimal machine parameters save time and reduce component stress

In addition to data preparation software, machine communication software also influences the quality and success of metal additively manufactured parts. With the Materialise Build Processor users can divide parts into a hull and a core, with each being built with a different scanning strategy. Build Processors can also assign different scanning strategies to different types of support structures. For instance, support structures can be scanned every two layers, speeding up the scanning process and reducing stress.

With Materialise's Build Processor, Control Platform and Inspector software, the user can fully control the metal Additive Manufacturing process.





Fig. 8 This titanium demonstration part is a spider bracket that connects the corners of architectural glass panels used in atria and floor-to-ceiling glazing. The inset image shows the solid mesh with lattice structures

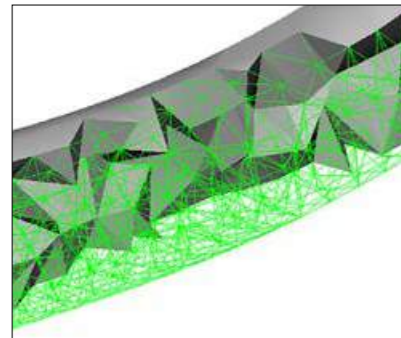

Fig. 9 Rough data prior to transformation

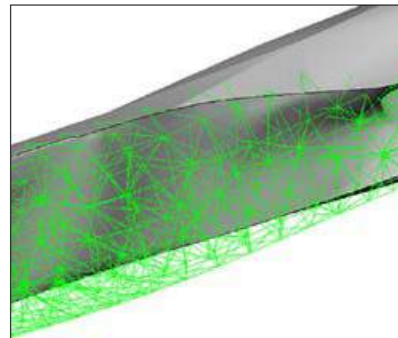

Fig. 10 The final clean model with smooth surfaces

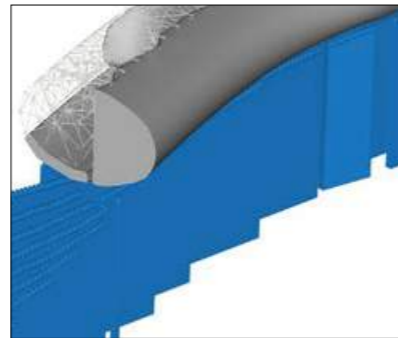

Fig. 11 Additional solid material placed under the lattice

They can inspect the build process strategy, monitor and log data in real time and save valuable time and material with a root cause analysis of failed builds. The goal is predicting and detecting errors with less effort and increasing overall confidence in the quality of the finished metal parts.

### Case study: Design and manufacture of a spider bracket

This case study highlights how a topology-optimised metal spider bracket was successfully developed and manufactured (Fig. 8). Together,

design enhancement software, data preparation software and machine communication software lead to an impressive titanium AM part.

Materialise worked together with Altair and Renishaw to create this component. The original design was based on brackets that connect the corners of architectural glass panels used in atria and floor-to-ceiling wall glazing. The bracket contains a hybrid lattice structure that could not have been created with conventional manufacturing methods. The success of the finished part is due to the application of Altair's lattice-based optimisation software, Materialise's Magics, 3-matic and Build Processor

software and the advanced capabilities of Renishaw's metal AM system.

The spider bracket's design mimics the biological structures that can be found in nature. Altair's topology optimisation software created a unique, organic shape that is both light and strong (Fig. 8 inset). The lattice structures also provide enhanced stability and improved thermal behaviour. However, topology-optimised models need sufficient smoothing prior to final manufacturing.

Topology optimisation resulted in solid regions and regions with a lattice structure. The irregular interface between the lattice and the

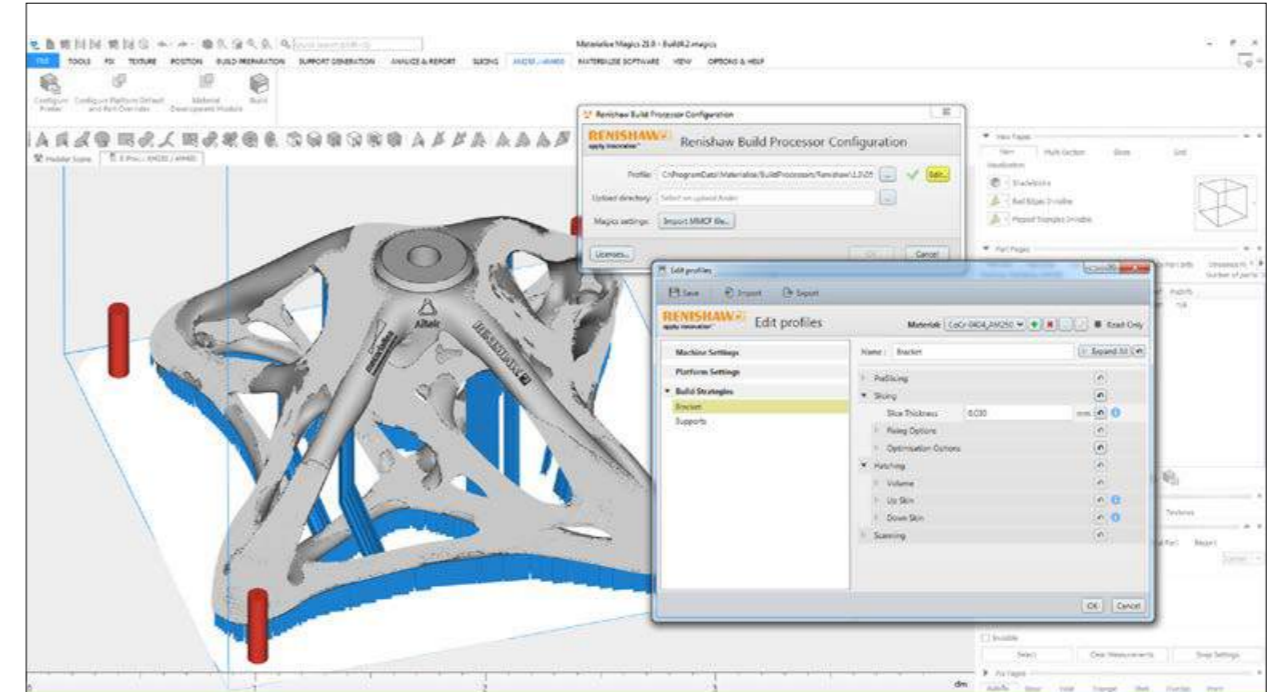

Fig. 12 Screen shot of the Build Processor software during the spider bracket project

solid mesh makes Additive Manufacturing difficult and can lead to stress accumulations. This means that the edge geometry needed reconstruction. It was here that Materialise's 3-matic design optimisation software for Additive Manufacturing was used and the design engineers at Materialise easily transformed the rough data (Fig. 9) into a clean model with smooth surfaces (Fig. 10).

Besides the irregular geometry, the support structures attached to the lattice could potentially cause problems during the laser melting process. For instance, when the supports are removed, there is a risk that some of the lattice structure could break off as well. To prevent this issue, Materialise engineers placed a thin layer of solid material under the lattice structures that needed support (Fig. 11). In certain regions, the design was also enhanced with Materialise 3-matic to reduce the numbers of support structures necessary.

After these design enhancements, engineers used Materialise Magics to add the logos of the three companies, find the optimal orientation, position the part within the build envelope and generate support structures. Normally such a large and complex

data set would be difficult to process and manipulate. In this case, the calculation of the structures was postponed until the slicing step. The slice-based technology of the Renishaw Build Processor, powered by Materialise, applied the 3D geometry of the spider bracket at the slice level instead of at the STL level, which kept the file size remarkably low.

The build file was therefore sliced and tested according to the material parameters assigned by Renishaw (Fig. 12). After this, the model was turned into a titanium part thanks to the expertise and technology developed by Renishaw.

The striking bracket was built successfully, translating almost 4 GB of data. The never-seen-before



Fig. 13 Metal support structures generated with Materialise Magics (Courtesy Altair, Materialise and Renishaw)



Fig. 14 A metal AM heat sink manufactured in aluminium for an industrial application



Fig. 15 A patient specific titanium HIP implant produced by AM

design and unique mix of solutions that were used provide an insight to the new era of shapes and products to come in metal Additive Manufacturing.

### Markets for metal AM: key application examples

#### Heat Sinks

Heat exchangers are designed to dissipate heat, for example the heat generated by electronic and mechanical devices (Fig. 14). The surface area highly influences the performance of the heat sink, but typically the available space is rather limited. That means maximising the surface area within the dimensional boundaries is the key challenge.

The design freedom offered by Additive Manufacturing allows for the creation of thin, complex geometries and lattice structures that make optimal use of the available space. Combined with the excellent thermal conductivity of additively manufactured aluminium, heat sinks are an especially well-suited application.

#### Spare parts

The demand for spare parts is typically intermittent and it is difficult to forecast when specific parts will be needed and where. Keeping those parts available on the shelves is a costly operation, requiring storage for the parts and the retention of tools. Additive Manufacturing allows for on-demand and local production of

spare parts, avoiding inventories and transforming entire supply chains.

To fully profit from the technology in terms of material usage, weight and functionality, a redesign is recommended, but, as more companies adopt Additive Manufacturing for initial production, the management of spare parts will become simpler.

#### Structural components

The fields of bionics and structural optimisation show a great potential for industrial applications. Structures generated as a result of topology optimisation often lead to highly complex shapes. By making use of the geometrical freedom that Additive Manufacturing offers, these shapes can be realised with fewer manufacturing-related restrictions or adaptations. Given the excellent mechanical properties of additively manufactured metal parts, this results in structural components that reduce the overall weight and material waste without compromising strength. This approach offers significant possibilities in the design of structural components.

#### Tooling components

In the tooling industry the pressure on costs is high. Controlling those costs can be done partly by optimising the part throughput of the machine and partly by reducing waste. One solution is the use of conformal cooling. By making tools through Additive Manufacturing, highly complex internal cooling channels can be integrated close to a part's surface. This results in an optimised heat flow and time gains during cool down, reducing the risk of warpage, improving part quality and shortening the production cycle of parts.

For parts that are so complex that conventional manufacturing methods would require labour-intensive and costly tools, direct production in Additive Manufacturing can be beneficial.

#### Medical devices

Mass customisation can be implemented sustainably only through Additive Manufacturing, where design flexibility does not compromise

cost-effectiveness. For this reason, the medical industry was one of the earliest adopters of Additive Manufacturing to make custom parts such as implants and personalised medical devices (Fig. 15).

The biocompatibility of AM titanium, combined with the ability to create complex structures, has opened new opportunities to minimise surgical impact, stimulate bone ingrowth and improve a patient's mobility. At that level of patient-specific customisation, Additive Manufacturing is the only technically feasible and cost-effective production method.

#### Food processing

Food processing companies are often in need of custom-made parts. Making tools for these small series often raises production costs. The manufacturing cost of Additive Manufacturing, which is not dependent on series volume, offers ways to keep costs down.

Additionally, the biocompatible nature of AM titanium allows for direct contact with foods and liquids. Combined with the design flexibility, this gives room for more functional and complex components used in gripping, feeding and depositing food products. By integrating functionality, the number of components can be kept lower, reducing the risk of downtime and the need for maintenance.

#### Fashion and design

Attracted by the ability to design exceptional shapes and geometries, for both aesthetics and functionality, designers and artists have been experimenting with Additive Manufacturing since the early days of the technology. With metal Additive Manufacturing becoming more accessible, doors opened to create things that were previously unthinkable. Personalised jewellery, eyewear, design objects and accessories can be made in an ever-growing range of materials and finishes. In a sector where brands require rapid design upgrades to maintain market competitiveness, Additive Manufac-



Fig. 16 A design optimised aluminium suction gripper for an industrial automation application

turing is a rewarding choice owing to profitable low-volume production runs and fast lead times.

#### Industrial automation

Every project in industrial automation comes with its own requirements, calling for a custom solution. Additive Manufacturing addresses this challenge through cost-effective production of small series and unrestricted design possibilities. Complex integrated functionality allows grippers and clamping devices to use fewer components and less manual assembly. In the component shown in Fig. 16, volume optimisation results in a lightweight and inexpensive gripper that allows robots to work at optimal speed. The high strength and low weight of AM aluminium makes it a good fit for durable customised automation solutions, while stainless steel can be used for food-safe applications.

#### Conclusion

What is clear from these application examples is that all sectors of industry are now starting to recognise the opportunities that are presented by Additive Manufacturing. One of the most significant challenges facing those who are looking to move into component production is how to reduce the steep learning curve associated with a process that is so

radically different to conventional technologies. It is important that new entrants to this field recognise that software is a key additional consideration when starting out on the AM journey - this article just touches on two aspects of what specialist software for AM can offer.

The requirement to start with an AM machine is obvious, as is the need for appropriate materials, but all too often the advantages that software solutions can bring - and the impact that they can have on reducing speed to market - are realised very late in the day.

#### Contact

Materialise NV  
Technologielaan 15  
3001 Leuven  
Belgium  
Tel: +32 16 39 66 66  
software@materialise.be  
www.materialise.com

All images courtesy of Materialise



**ADDITIVE MANUFACTURING**

**WITH POWDER METALLURGY**

**June 13-15, 2017, Las Vegas, Nevada**

*Focusing on metal additive manufacturing, this conference will feature worldwide industry experts presenting the latest technology developments in this fast-growing field.*

**Perspectives from:**

- end users
- toll providers
- metal powder producers
- equipment manufacturers
- R&D from academia and consortia

**Topics will cover:**

- materials
- applications
- technical barriers
- process economics
- new developments

**Exhibition:**

- trade show featuring leading AMPM suppliers



The Bellagio Hotel

Held in conjunction with:



Visit [AMPM2017.ORG](http://AMPM2017.ORG) for more details.



## EOS GmbH: Transforming companies into AM champions with Additive Minds

EOS GmbH, based in Krailling, near Munich, has long been recognised as a leader in powder bed Additive Manufacturing technologies for both metals and plastics. The launch of its Additive Minds training and consultancy service, however, represents a significant expansion of the support that the company can offer to those entering the industry. Nick Williams talks to EOS's GÜNGÖR KARA, Director of Global Application & Consulting, on the evolution of the metal AM industry and the changing approach that customers are taking to implement the technology.

When *Metal Additive Manufacturing* magazine visited EOS GmbH's headquarters in Krailling last summer, the site was busy with the construction of a third large administrative building. The main technology and customer centre that the company inaugurated in 2014 represented a substantial expansion at the firm's headquarters, however this latest phase of development has resulted in the creation of a much larger, vibrant and modern campus dedicated to AM. Set in an attractive rural environment, the campus is less than half an hour from Munich's city centre. The company's workforce has also continued to grow and in January this year the milestone of 1000 employees worldwide was reached, doubling that of just three years ago. New production facilities are also planned and the company's regional offices are also expanding.

It has, however, not only been the company's physical infrastructure and employee count that has expanded to keep up with industry demand. With the announcement of its Additive Minds offering in late 2016, the company is seeking to position itself as a leading supplier for AM training,

application development, consulting and technology implementation.

Additive Minds is led by EOS's GÜNGÖR KARA, Director of Global Application & Consulting. Following the announcement about the new Additive Minds service at Formnext 2016, *Metal AM* magazine met with Kara, where discussions focused on the

new venture's roots and objectives. This article picks up on a number of themes that were highlighted in those discussions. What is clear is that the Additive Minds concept is a timely expansion of the support that EOS has always offered to its customers in their development and implementation of AM.



Fig. 1 EOS's headquarters in Krailling, near Munich (Courtesy EOS)



Fig. 2 Additive Minds' Gungör Kara (Courtesy EOS)

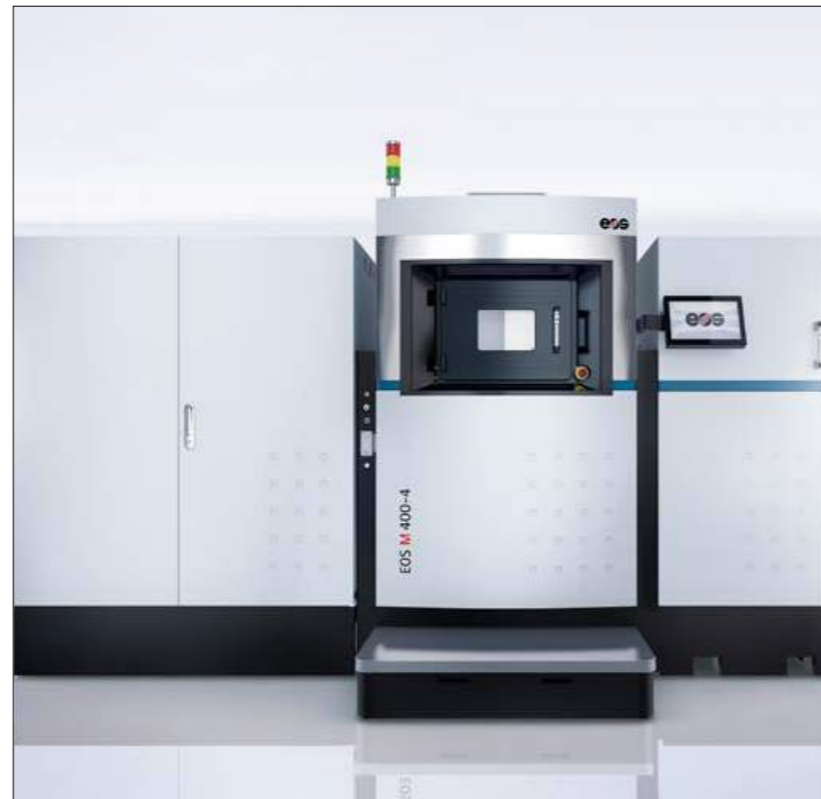

Fig. 3 The M 400-4 is the company's flagship metal Additive Manufacturing system (Courtesy EOS)

### The Additive Minds approach to supporting AM development

Additive Minds has been structured to offer a wide range of support options for those looking to make the move into metal AM. These options range from straightforward employee training through to comprehensive application development support and complete facility planning. The Additive Minds service is based around three core areas that can support company's move into metal AM; Consulting, Innovation Centres and its Customer Academy.

Explaining the evolution of the Additive Minds concept, Kara stated, "Initially, we expanded our conventional sales and support offerings through consulting as it became clear that many of our customers still needed a significant level of educational support. This support often went far beyond the basic training we were initially offering and as this service grew it became clear

that we needed to give it an identity of its own, so Additive Minds was born. With our training and customer specific consulting we can now support customers at all stages of the AM learning curve. We can enable and support all the necessary steps to develop an application, from an initial introduction to AM technology to supporting application redesigns, application-specific parameter development, operational qualification and in-process quality observance via our MeltPool monitoring tool."

#### Additive Minds Innovation Centre

With its Additive Minds Innovation Centre, EOS has significantly extended its range of services in the area of AM support and has created what it calls a 'central hub of innovation'. Companies can send a team of engineers and technicians to EOS where experts from Additive Minds oversee their education and development for a period of six to eighteen months. During this time, there is the potential to develop new applications

through to a production stage. At the end of this phase, a team will have the capability to immediately continue production in their own company, thus gaining a huge time advantage.

"Developing applications for serial production can be a challenging task for a company that is new to the technology. Therefore, large organisations are now taking advantage of going through this development journey with an industry partner who not only supports but also enables them towards AM serial production," stated Kara. "This is what we do with our Additive Minds Innovation Centre. Jointly with the customer, we initiate the development process by finding the right application for production using AM technology. Once identified, we then develop this application jointly with the customer's engineers. As a result of this collaborative approach they have learned enough to enable them to develop further AM applications by themselves afterwards. This type of process normally happens either in our Innovation Centre at our



Fig. 4 The Munich-based Additive Minds team (Courtesy EOS)

headquarters in Krailling, in different regional EOS Innovation Labs around the globe, or on a customer site as a private Centre of Excellence."

#### Additive Minds Consulting

The Additive Minds consulting service addresses each customer's individual requirements. The range of topics on offer covers the complete cycle, from technology fundamentals, component choice for AM production, design and AM-compatible engineering to production scaling and validation.

"If an even more holistic approach is needed, we can accompany customers with a dedicated team of Additive Minds Consultants through the development of serial applications to starting serial production within one continuous project. This is the approach taken by our Innovation Centre team," explained Kara.

#### Additive Minds Academy

The Additive Minds Academy additionally offers a range of AM training courses and workshops that can

range from two days to six months. These courses cover all aspects of AM technology, from part screening and selection through to parameter editing, lattice structures and melt pool monitoring.

EOS has developed its own training programme in collaboration with the University of Wolverhampton and the SRH Hochschule Berlin. Through this, participants can qualify as an AM Application Engineer within six months through intensive learning modules and practical training. The first participants began their course in February 2017. "Educating and training AM Application Engineers can also be challenging as customers currently very often go through a 'trial and error' learning curve that is very time consuming and ties up resources. Because of this, we introduced our training programme, helping to prepare our customers for the next steps in introducing AM in their organisation and enabling them to tap the full potential of this disruptive technology," stated Kara.

### Speeding up the development cycle

Those who have already gone through the process of developing an AM application in-house for the first time will recognise that the length of the development cycle can be critical to the success or failure of a project. Budgets and patience are limited in all organisations and managing expectations, be they at board level or R&D level, is vital. A timescale of two years is often given in the industry in order to develop an application in-house for series production. Commenting on the typical timeline that a company should expect for a project to reach series production at a new in-house facility, Kara stated, "Our experience shows that customers who work with Additive Minds Innovation Centres can enter AM-based serial production within a timeframe of six to eighteen months."

"The biggest initial misconception we see among newcomers to our technology is in relation to the



Fig. 5 The Krailing headquarters and campus is based in a rural location 30 minutes from the centre of Munich (Courtesy Mayr | Ludescher | Partner, Munich)

complexity of building up the knowledge and experience that is necessary to succeed in AM. Today, there is still a low number of engineers in the market who can develop AM applications. Therefore, knowledge must be built up and scaled internally in every organisation. We see a lack of AM knowledge - and not taking seriously how important this is - as one of the key factors that contributes to the failure of ventures into AM. Investing into AM education and enablement is crucial as it will help the customer to better understand what they didn't know before. Customers will get a better understanding of what AM can offer in general, as well as to their business. At the same time, they will also get a better feeling of what hurdles their organisation might have to overcome on the way to success," stated Kara. "It is unsurprising that a customer needs to observe both sides of the coin to be successful. With every innovation that a company introduces, it will

be entering new and unknown fields that will challenge the mindset of what was previously clear and certain. Once a customer understands the beauty of this innovative technology, we invite them to share the passion that we at EOS have for its possibilities."

"In the past, a lot of effort went into helping customers who had achieved a certain level of expertise in AM by themselves, but had then hit obstacles that were simply beyond their capabilities. The inevitable result was that many of these early entrants lost momentum in their projects because of the complexity of the challenges that faced them. Now, by placing an emphasis on support from a very early stage, we can help to rapidly increase a company's knowledge through a variety of routes and make them aware at a very first stage of their journey not only what is possible, but what the restrictions are too," added Kara.

"We have seen inflated expecta-

tions guide decision processes. It goes without saying this will lead to disillusionment over the process of introducing AM to a business. However, once the reality of AM is clearer for your organisation, once your people are trained and educated, the application is defined and the AM strategy clear, the first successes will come - celebrate them! We have a growing number of customers that already entered a phase where they have become truly successful with their decision to make a strategic investment into AM," stated Kara.

Companies introducing AM have to act in a very agile way to adapt to this new and disruptive technology. If they do not, they are more likely to fail. "Business models based on AM also need to be disruptive to make the use of AM a true and sustainable success story. In total, organisations constantly need to innovate - in the case of AM this will require an openness to disruptive change - but which will pay back in the end."

## Audi and Additive Minds

EOS recently announced a development partnership with Germany's Audi AG, one of the leading manufacturers of premium automobiles, to support the carmaker in the holistic implementation of industrial Additive Manufacturing technology and the development of a corresponding Additive Manufacturing centre in Ingolstadt. "The aim is to not only supply Audi with the right additive systems and processes, but to also support them during applications development, when building up internal AM knowledge and training their engineers to become in-house AM experts," commented Kara.

Audi has recognised the potential of Additive Manufacturing in the automotive industry for some time and now actively promotes the use of the technology within its business. The company's toolmaking and casting technical centres play a leading role in these activities thanks to the advantages of conformal cooling, for example. AM is, however, also being applied to equipment and prototype manufacturing at Audi, as well as for motorsport applications.

Jörg Spindler, Head of Toolmaking at Audi, explained, "We have set up our own competence centre for 3D printing in order to gain experience with the materials and the process and to further develop them for series production. A close cooperation with AM solution providers such as EOS, who can support innovation in technology development, is essential for these aims. With this technology we are able to integrate internal structures and functions in tools that we have not been able to create so far with conventional manufacturing methods. Especially with components in small batches, we can now produce components using lightweight construction, quickly and economically based on this technology."

With the application of Additive Manufacturing, Audi is also focusing on the production of inserts for die casting moulds and hot working segments. The company can positively influence series production processes



Fig. 6 Metal AM production at Audi using an EOS M 290 (Courtesy Audi AG)



Fig. 7 Tooling and components produced by Audi using AM (Courtesy Audi AG)

through conformal cooling, producing parts and vehicle components more cost-effectively. This is made possible by using highly complex, additively manufactured cooling channels, which are tailored to the component and could not be implemented using conventional technologies. Specifically, the optimised cooling performance leads to a reduction of cycle times by 20%, which has a positive effect on energy consumption and the cost of components.

Dr Stefan Bindl, Team Manager at the Additive Minds Innovation Centre, stated, "The close cooperation concerning application and process

development, as well as internal knowledge building, makes a significant contribution, which is why Audi can quickly achieve substantial positive effects for their own business by applying our technology."

## Industry's evolving approach to AM

EOS has seen some significant changes over the last decade in terms of how customers evaluate and use metal AM. "In the first twenty years since the foundation of EOS, in 1989, we saw customers using our tech-

nology primarily for rapid prototyping with the sole aim of accelerating product development and speed to market. Today, we see more and more companies investigating how they can use our technology for true serial applications. The challenges they face and the support they need from us are completely different from those early rapid prototyping customers," stated Kara.

"What is critical today to the successful implementation of metal AM is that companies define one, or several, applications where the use of the technology can be most beneficial. In parallel, they must build up their knowledge as their engineering staff typically have no experience of AM technology. Once a company has implemented AM it needs to prepare itself to act in an agile way to be able to adapt adequately to its customers' requirements for AM parts," stated Kara.

Kara believes, however, that the number of companies with a deep knowledge of AM technology is still extremely low. Consequently, today only a few can develop truly radical innovations with AM. "Additive Manufacturing is, however, constantly gaining more awareness as we progress and the potential of the technology is therefore becoming more known. It is a great enabler of radical innovations. It can disrupt markets and create competitive advantages by introducing new business models. To leverage this effect, organisations must focus now on building up expertise. This allows organisations to become the first mover within their industry sector, blocking others from following, as building up IP for AM applications is almost impossible to surpass," stated Kara.

Kara added that in addition to the potential of AM in terms of design, part integration, customisation and supply chain, companies must also focus on the effects that the technology can have on their markets. "We urge companies to consider the development of AM business models to derive the best possible from this new technology. Companies planning to use AM for serial applications

normally have to undergo a substantial transformation to successfully introduce this disruptive technology in their business in a way that it can truly become successful and add value. If start-up teams do not keep an eye on how the market is developing around them, they might run the risk of being overtaken quite quickly."

### Outlook

The metal AM industry is evolving at tremendous speed in terms of process, application and material developments. EOS stated that in recent years it has developed a far clearer understanding of what the greatest needs of its customers are in relation to scaling up AM. Looking to the future, key areas for development activity have been identified as:

- Increasing the productivity, scalability and automation of production systems
- Offering an ever-growing choice of new materials
- Integrating conventional and additive technologies in existing manufacturing environments at the customers' operations.

"In addition to these topics, we will be constantly improving the support that we offer to our customers, where the number of disruptive innovative AM applications will continue to grow," stated Kara.

Commenting on GE's investments in Arcam and Concept Laser, Kara stated that this move in the AM market had not taken EOS by surprise as it reflected the constantly altering competitive landscape in which the company is operating. "With the increasing industrial use of our technology we will see more and more players – including those from other industries – entering the scene. Moves like those of GE will additionally contribute to widening the perception, awareness and understanding of Additive Manufacturing across industries and shows the importance of the technology for the future of manufacturing."

GE, of course, has not been the only multinational company to make waves in terms of AM investments and application developments. Germany's Siemens is another example of a company that has innovated in the use of AM to enhance its industrial products. Commenting on what lessons others can learn from these businesses in terms of their approach to the adoption of metal AM, Kara stated, "Both of these companies stepped into this emerging market very early and, as such, have been able to build up specialist knowledge and experience. Today, this gives them a clear competitive advantage. Another result of this is that they now have an IP advantage to block other competitors from entering their AM-driven market. This block is almost impossible to skip and leaves others limited to entering other fields of businesses."

Through its new Additive Minds service, EOS is well positioned to be a first point of contact for those looking to evaluate AM. This naturally places the company in a strong position when hardware investment decisions are made. Kara concluded, "I believe that we now support our customers with the most extended AM enablement services in the industry. With this, we can ensure that our customers go through their AM transformation adequately supported and successfully to become the AM champions within their industry."

### Contact

Güngör Kara  
Director of Global Application and Consulting  
EOS GmbH Electro Optical Systems  
Robert-Stirling-Ring 1  
82152 Krailling/Munich  
Germany

Tel: +49 89 893 36 0  
Fax: +49 89 893 36 285  
www.additive-minds.com  
www.eos.info

## the most **influential event** in **3D manufacturing**

The two industry leaders in 3D technology events, SME and Rapid News Publications Ltd., are teaming up to bring you **RAPID + TCT**. The event will be the premier destination for innovation, education, collaboration and networking in 3D manufacturing.



### why **attend?**

- **Learn** how to use 3D technologies to reduce time to market, produce stronger and lighter parts, improve efficiency, and create complex geometries.
- **Consult** with industry experts before you make equipment decisions.
- **Visit** hundreds of 3D technology manufacturers in one room.
- **Network** with thousands of attendees and see how they're addressing challenges.

Visit [rapid3Devent.com](http://rapid3Devent.com) to learn more



# EMO



## Hannover

The world of metalworking

*Connecting systems for intelligent production!*

INFO:  
VDW – Generalkommissariat EMO Hannover 2017  
Verein Deutscher Werkzeugmaschinenfabriken e.V. · Corneliusstraße 4 · 60325 Frankfurt am Main · GERMANY  
Tel.: +49 69 756081-0 · Fax: +49 69 756081-74 · emo@vdw.de · www.emo-hannover.de



## The science behind a basic consumer product: Bottle openers by metal Additive Manufacturing

Bottle openers manufactured by metal Additive Manufacturing have become a popular promotional gift, with a variety of designs produced by AM technology suppliers. In the first of a new series of design oriented articles for *Metal Additive Manufacturing* magazine, Olaf Diegel and Terry Wohlers reveal how these products effectively demonstrate several key concepts that designers need to understand in the development of parts for production by metal AM.

Bottle openers have long demonstrated the benefits of Additive Manufacturing. Methods of topology optimisation and lightweighting, coupled with 'complexity for free', clearly show what is possible with metal AM. Also, they make a great gift that people will use and enjoy showing to others when discussing the subject of Additive Manufacturing (Figs. 1, 2). But what do these bottle openers really show and is it possible to quantify some of their benefits to truly grasp the advantages offered by Additive Manufacturing? Are they little more than a trinket or do they really reveal the power and utility of metal AM?

Conventional manufacturing processes are typically sub-optimal in their use of material. This is because the shape of a part is largely driven by the ease of the manufacturing process. A lack of design optimisation reveals itself when a stress analysis is performed. Some regions of a part will be highly stressed, while others have very low stress values, indicating that too much material is present. The

geometric freedom offered by AM enables parts to be designed to the same functional specifications as conventional parts but with less material. This is often referred to as lightweighting a part. Approaches to lightweighting can be performed

using standard CAD methods, such as reducing the thickness of features in low-stress regions. However, to achieve a high degree of weight savings across an entire part, topology optimisation is required.



Fig. 1 Bottle openers by 3D Systems (top) and Renishaw (bottom)



Fig. 2 Bottle openers (from top to bottom) by ReaLizer, Premium AEROTEC, and Olaf Diegel

### Topology optimisation overview

Topology optimisation is letting mathematics decide where to put the material to optimise the strength-to-weight ratio. It seeks to use the least amount of material to sufficiently perform the job. Topology optimisation uses finite element analysis software at its core to make design decisions. The process usually

begins with a regularly shaped 'design space' for a part. The user then adds forces and constraints that the part will experience while functioning. Several different algorithms can be used to remove material from low-stress regions to arrive at a lightweight conceptual design.

Topology optimisation software produces a design idea that optimises the part

only for a particular set of load characteristics. As most products are subjected to a variety of different load cases, it is important to repeat the topology optimisation exercise for each particular load case. The bottle opener, for example, may have a worst-case load scenario in which only an upward force is applied at a point on the bottom of the handle, as used in the analysis in Figs. 4 and 5. It might have another load scenario in which all the force acts downwards on the handle. Each of these cases produces an entirely different design optimisation.

The end result of a complete topology optimisation process is the generation of a number of different design ideas, each optimised to withstand a particular set of forces. These design options can be combined to produce a final design that is optimised for all conditions.

Topology optimisation usually results in shapes that are organic in nature with many limbs and webs. The conceptual design usually needs to be refined using conventional CAD to improve its appearance and feasibility by removing impractically thin webs. It is often followed by shape optimisation to further refine the look and performance of a design. Topology optimisation is highly automated, so it can reduce development time substantially, compared to a conventional iterative design process.



Solid Steel Billet: 40 g

Solid Machined/Cast: 22 g

Topology Optimised AM: 8 g

Fig. 3 Weight comparison between CNC machined and additively manufactured bottle openers

### Weight reduction in Additive Manufacturing

When optimising a design such as a bottle opener, the first area of interest is weight reduction. If you were to make a metal bottle opener using traditional manufacturing techniques, you might, for example, machine it out of a solid billet of material such as steel. In the case of the bottle opener shown in Fig. 3, one might start with a solid block of steel, weighing about 40 g (1.41 oz), and mount it into a CNC milling machine. Using a relatively small cutter, the machine would mill away as much material as possible, resulting in a relatively simple bottle opener weighing about 22 g (0.78 oz). The 18 g (0.63 oz) of material that is milled away becomes scrap or is recycled, which requires further cost and energy.

In contrast, a bottle opener made by Additive Manufacturing, weighs only about 8 g (0.28 oz). This is less than one-third of the weight of the machined opener and one-fifth of the weight of the block of steel used to make the CNC machined opener. Also, the AM design produces only about 2 g (0.07 oz) of scrap from the support material that is used to anchor the opener to the build platform during the build process.

### Mechanical integrity considerations

Weight reduction is desirable, but only if it does not compromise the mechanical integrity of a part. Therefore, it is important to look at the mechanical properties of the topology optimised design and compare it with the conventional design. Most CAD software offers simple finite element analysis that allows one to examine the stresses on a part or the displacement that an applied force can cause. In a bottle opener, the jaw of the opener is normally fixed on the bottle cap while the handle is pulled up. The rigidity of the handle is important because it allows the user to exert the required

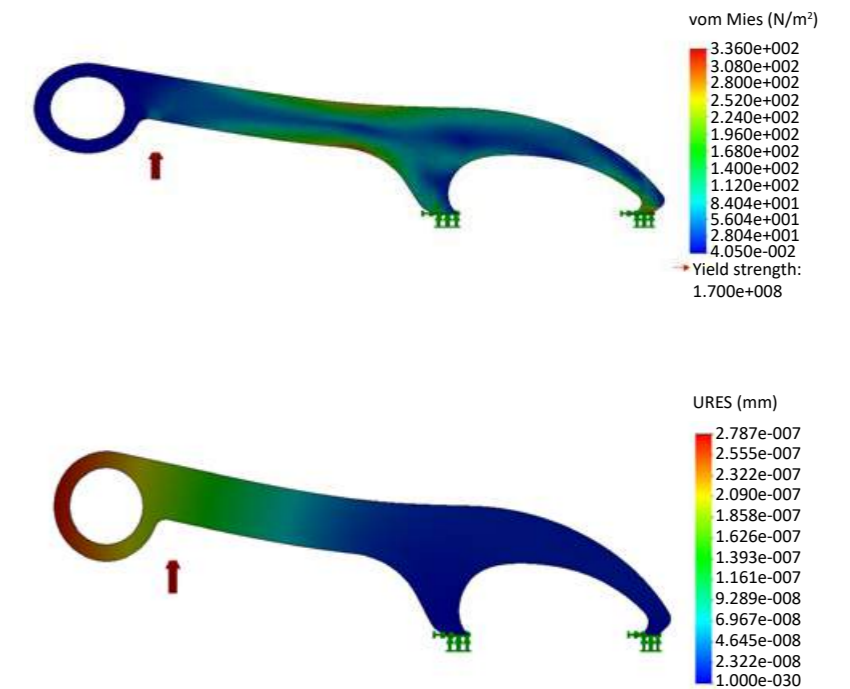

Fig. 4 Stress and displacement analysis of solid bottle opener under 100 N/mm<sup>2</sup> pressure

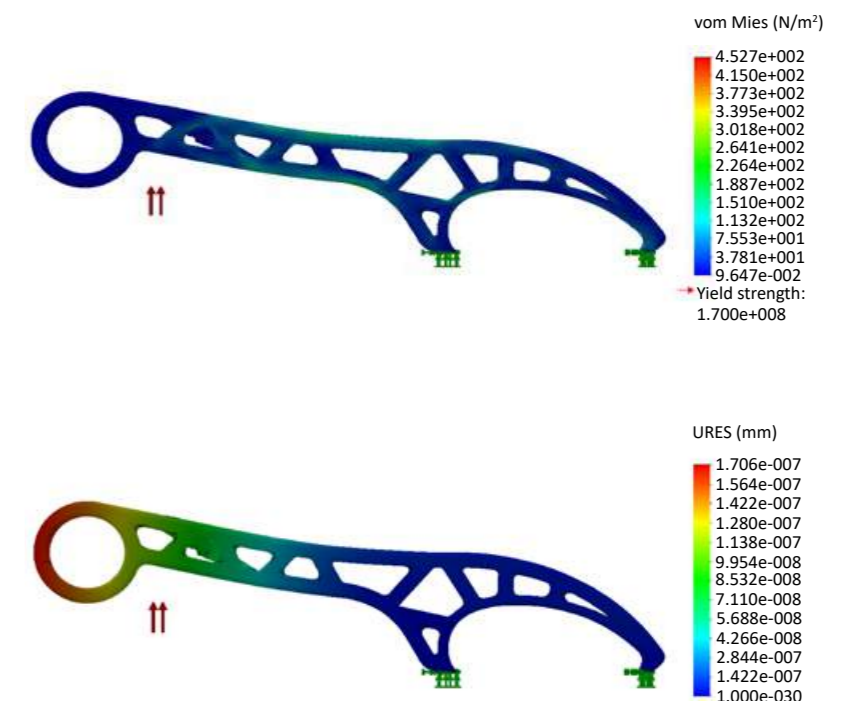

Fig. 5 Stress and displacement analysis of topology optimised bottle opener under 100 N/mm<sup>2</sup> pressure



leverage to remove the bottle cap. In the case of the bottle opener manufactured by CNC machining, a quick analysis (Fig. 4) shows that the displacement, caused by the lack of rigidity of the handle, from a pressure of 100 N/mm<sup>2</sup> results in displacement of about 2.7<sup>-007</sup> mm. In layman's terms, this means that if an upwards force of about 10 kg (22 lbs) is applied to the bottom left end of the bottle opener handle, the handle will bend up by an amount of about 0.0000003 mm.

In contrast, the topology optimised design (Fig. 5), under the exact same force conditions, shows greatly reduced stress, and a displacement of only 1.7<sup>-007</sup> mm. The result is about half the amount of bending of the solid design. This clearly shows that the optimised design has less

displacement than the solid design, and therefore offers a substantial increase in rigidity, which means that it will function better.

### Conclusion

On the surface, optimising bottle openers may come across as a frivolous exercise, but it serves as an excellent example of the potential offered by topology optimisation when coupled with Additive Manufacturing. It serves those learning about topology optimisation, lightweighting and AM and demonstrates what is possible. These methods of design can be applied to countless other parts and products at thousands of organisations around the world.

### Authors

Olaf Diegel and Terry Wohlers  
Wohlers Associates, Inc.  
Fort Collins  
Colorado 80525  
USA

wohlersassociates.com

Inovar Communications Ltd

Sign-up for our  
metal Additive  
Manufacturing  
e-newsletter

[www.metal-am.com](http://www.metal-am.com)



Download the latest issue  
of the magazine

powered by:

# formnext



International exhibition and conference  
on the next generation of manufacturing technologies

Frankfurt, Germany, 14–17 November 2017  
[formnext.com](http://formnext.com)

Do the right thing  
today for tomorrow

With its unique combination of conventional technologies and additive manufacturing formnext brings visitors from all over the world to Frankfurt am Main. Here the manufacturing industry experiences the next generation of intelligent industrial production.

Set the course for your company's future today and secure your exhibition space now.

Where ideas take shape.

Earlybird rate until 10 March 2017  
10% off on exhibition space



[formnext.com/exhibitorkit](http://formnext.com/exhibitorkit)

Information:  
+49 711 61946-825  
[formnext@mesago.com](mailto:formnext@mesago.com)

Follow us



@formnext\_expo  
#formnext



XING



mesago  
Messe Frankfurt Group

# POWDERMET2017



## 2017 International Conference on Powder Metallurgy & Particulate Materials

June 13-16, 2017  
The Bellagio • Las Vegas

### TECHNICAL PROGRAM

Over 200 worldwide industry experts will present the latest in powder metallurgy and particulate materials.

### TRADE EXHIBITION

Over 100 companies showcasing leading suppliers of powder metallurgy and particulate materials processing equipment, powders, and products.

### SPECIAL CONFERENCE EVENTS

Including special guest speakers, awards luncheons, and evening networking events.

Held in conjunction with:



POWDERMET2017.ORG



METAL POWDER INDUSTRIES FEDERATION  
APMI INTERNATIONAL



## Accelerating AM component design workflow with new optimisation technology

Additive Manufacturing promises huge benefits for industry, but exploiting these in practice can prove difficult. For example, although truss-like component forms will often be found to be much more structurally efficient than traditional forms, identifying these has thus far been laborious and time-consuming. However, a new optimisation approach means that engineers can now directly identify optimised truss forms for AM components, saving time and effort. Prof. Matthew Gilbert of LimitState and the Advanced Additive Manufacturing (AdAM) Centre at the University of Sheffield outlines the technology and its application.

Additive Manufacturing processes are developing rapidly and are now increasingly being used to produce high value metallic components for the aerospace, automotive and space sectors. In parallel, structural optimisation techniques are also maturing rapidly and engineers can now identify the optimal form for many problems. These new forms are often geometrically complex, and are ideally suited for AM fabrication.

In recent years, engineers have used topology optimisation techniques to generate optimal forms using tools such as Altair OptiStruct and Inspire. This approach works well when the component occupies a relatively large proportion of the available design space - when the so-called 'volume fraction' is quite high. However, when the volume fraction is low, a fine numerical discretisation is normally required to identify the optimal form, which is computationally expensive. Worse, designers then have to perform time-consuming manual post-processing to deliver a clear

component form and this can make the design workflow in Additive Manufacturing uneconomic for many companies. However, there is now an alternative means of generating truss-like forms that is significantly more direct and efficient.

### A discrete optimisation approach

This new alternative to conventional topology optimisation involves a discrete (line-element) optimisation approach, employing layout optimisation (LO) and geometry



Fig. 1 A metal AM isostatic mount for a satellite optimised with LimitState:FORM software

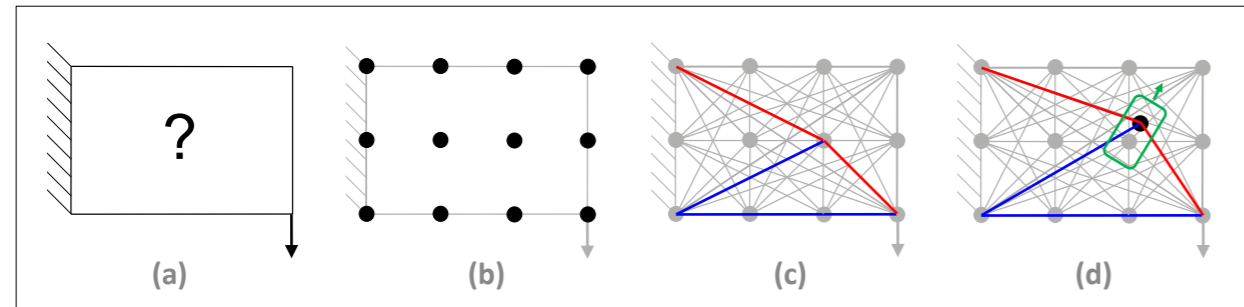

Fig. 2 Discrete optimisation approach: (a) specify design domain, loading and support conditions; (b) discretisation using nodes; (c) interconnect nodes with line elements and use layout optimisation (LO) to identify the optimal arrangement of discrete members (shown in red/blue); (d) adjust joint positions to improve the solution (geometry optimisation, GO)

optimisation (GO). This works particularly well when the engineer has a high degree of design freedom, as truss-like forms will generally be found to provide the most efficient design solutions. Smith *et al.* [1] recently demonstrated the approach, employing LO to obtain AM component designs. Also, GO can now potentially be applied in tandem with LO to obtain improved solutions, as described by He *et al.* [2]. The combined approach is shown in Fig. 2.

Once a line-element representation has been obtained, this can readily be transformed into a continuum model, suitable for further verification or manufacture, as indicated in Fig. 3. There are four key benefits of this discrete, line-element, optimisation approach:

- Engineers can automatically generate a high-quality solid geometry CAD model, rather than a mesh geometry
- Engineers can take steps to ensure that the optimised design is easy to be manufactured using AM processes. For example, they

can specify in the optimisation that members should not be inclined at shallow angles to the horizontal

- Engineers can easily check the absolute structural efficiency of the design, based on the subtended angles between members
- Engineers can rapidly perform structural checks on the optimised form, such as global buckling stability checks.

As ever, there is a trade-off between computational efficiency and optimisation capability. A pragmatic approach, adopted in the recently released LimitState:FORM software, is to use a relatively simple optimisation formulation - linear in the case of the LO phase. As a result, engineers can obtain solutions extremely quickly, typically in seconds or minutes. Engineers can then easily edit and analyse the resulting optimised line-element model, for example adjusting the design to remove thin elements, or

checking global buckling stability. The discrete optimisation approach means that engineers can obtain a viable design very quickly after an initial optimisation. This is typically not the case when using topology optimisation.

### Examples

The simple beam design shown in Fig. 4 was obtained automatically using LO, and was shown, through load testing [1] to be capable of carrying the target design load. In this case, specimens were manufactured using titanium Ti-6Al-4V via the Electron Beam Melting (EBM) process.

The discrete optimisation approach was also recently used to develop a new airbrake hinge design for the Bloodhound supersonic car project, as shown in Fig. 5. The resulting design is almost 70% lighter than the original. Also, the use of GO and the ability to interactively edit the solution using LimitState:FORM led to a simpler form compared to that proposed previously by [1].

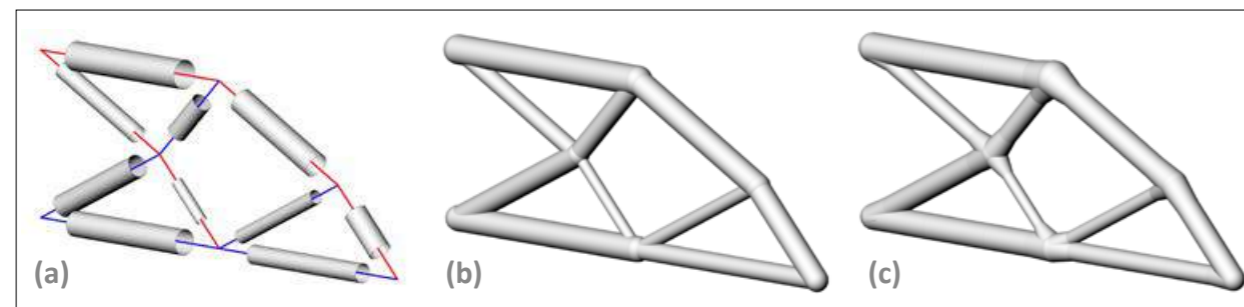

Fig. 3 Conversion of a line-element structure into a continuum (after Smith *et al.*, 2016): (a) loft elements (e.g. as cylinders); (b) add joints; (c) expand joints to avoid stress concentrations

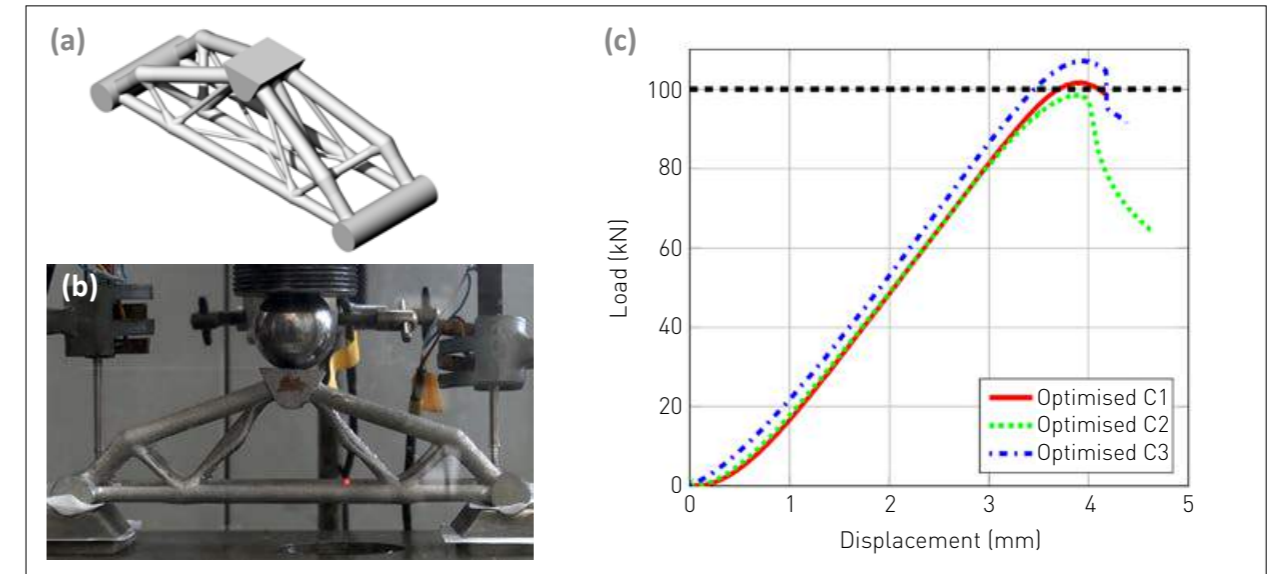

Fig. 4 Simple beam (after Smith *et al.* 2016): (a) design; (b) fabricated component during a load test, and (c) load vs. displacement responses of tested components (target load = 100 kN)

### Conclusion

LimitState now offers a rapid and effective alternative to traditional optimisation techniques for AM components. The new discrete optimisation approach speeds up the process of identifying structurally efficient designs and is particularly suitable for problems where there is significant design freedom.

Discrete optimisation offers several key advantages over existing topology optimisation:

- There is no need to specify a volume fraction in advance, avoiding the need to find an appropriate value by trial and error
- Solutions can be obtained more rapidly, typically in seconds or minutes, rather than hours or days
- It is possible to interact with the resulting optimised design, and to perform verification checks
- The need for time-consuming remodelling of the solution is significantly reduced.

The approach helps to address one of the main obstacles to widespread adoption of AM, and the use of lightweight forms in manufacturing.

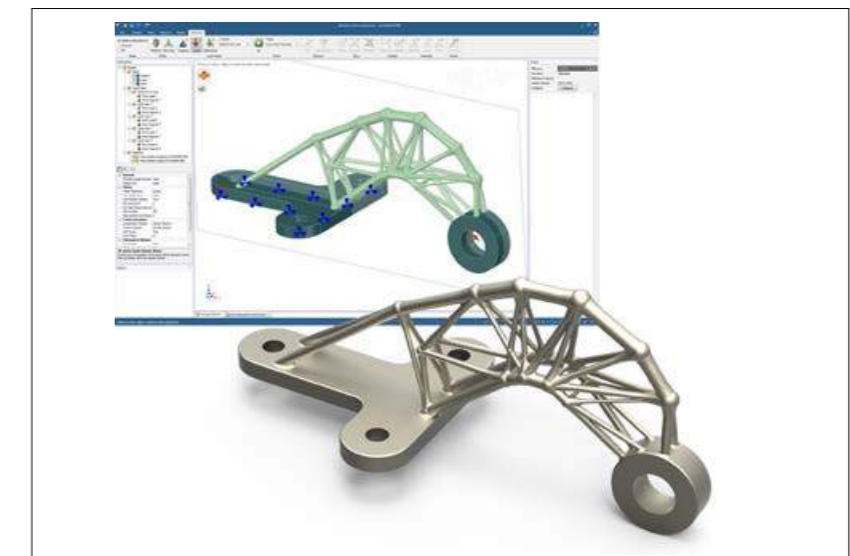

Fig. 5 New design for Bloodhound airbrake hinge, obtained using the LimitState:FORM software

### Author

Matthew Gilbert  
LimitState Ltd  
217 Portobello  
Sheffield S1 4DP, UKEmail:  
m.gilbert@limitstate.com  
www.limitstate.com

### References

- [1] Smith CJ, Gilbert M, Todd I & Derguti F, 'Application of layout optimization to the design of additively

manufactured metallic components', *Struct. Mult. Opt.*, 54(5), 1297-1313, 2016.

[2] He L, & Gilbert M, 'Rationalization of trusses generated via layout optimization', *Struct. Mult. Opt.*, 52(4), 677-694, 2015.

[3] LimitState Ltd, LimitState:FORM software, 2016. www.limitstate3d.com

The financial support of EPSRC (project ref. EP/K025775/1) and Innovate UK (ANVIL project, ref. 101483) is acknowledged.

China's largest PM &amp; MIM exhibition

# PM CHINA

SHANGHAI  
APRIL 26-28

2017

| Materials | Equipment | Products | Solutions |



Shanghai Everbright Convention &amp; Exhibition Center

PM CHINA 2017 Organizing Committee

Tel: +86-400 077 8909 | Fax: +86-21-23025505

Contact: Maggie Song | Email: pmexpochina@163.com

www.cn-pmexpo.com



## Additive Manufacturing at World PM2016: Opportunities for the use of water atomised metal powders

At the World PM2016 Congress, held in Hamburg, Germany, 9-13 October, 2016, two papers discussed the potential for the replacement of gas-atomised powders with water-atomised powders as the raw material for Selective Laser Melting of different alloy types. Dr David Whittaker reports on the work undertaken to assess the viability of the water atomisation process for these materials which could, in turn, offer significant cost savings.

**WORLDPM2016**  
congress and exhibition

### Microstructures and mechanical properties of Selective Laser-Melted metals with different processed powder

The first of these papers, from Naoyuki Nomura, Keiko Kikuchi and Akira Kawasaki (Tohoku University, Japan), considered the processing of Co-Cr-Mo alloys. Co-Cr-Mo alloys have been widely used as metallic biomaterials in applications such as bone fixation devices, artificial knee joints and dental appliances, because of their excellent strength and good corrosion resistance. Such alloys have been used in the as-cast state with slow cooling and, therefore, show limited ductility because of the precipitation of carbides in the inter-dendritic regions. Also, when carbon is not added to the alloy, a martensitic transformation from the  $\gamma$  phase (f.c.c) to the  $\epsilon$  phase (h.c.p) occurs during cooling after casting. The resultant  $\epsilon$  phase restricts further deformation. To improve ductility, the

Tohoku University group has developed a nitrogen-containing Co-Cr-Mo alloy, where nitrogen acts as a  $\gamma$  phase stabiliser. In alloys with added nitrogen, elongation was dramatically improved when nitrogen and chromium contents were increased in tandem. The group has also reported that the mechanical properties of a Co-29Cr-6Mo alloy were improved by applying a Powder Bed Fusion (PBF) process using a laser compared to a conventional dental casting. The  $\gamma$  phase was predominant in the SLM-built microstructure.

In the present reported study, the focus was mainly on the difference in responses of gas and water atomised powder variants. Co-33Cr-5Mo-0.4N (mass%) alloy powders were prepared by gas and water atomisation. A spherical particle shape with a smooth surface and dendritic traces was observed in the gas atomised powder, whereas an ellipsoidal particle shape with a dark contrast area was seen in the water atomised powder (Fig. 1). The median diameters ( $d_{50}$ ) of the gas and water atomised powders were 27.5  $\mu\text{m}$  and 24.5  $\mu\text{m}$ , respectively.

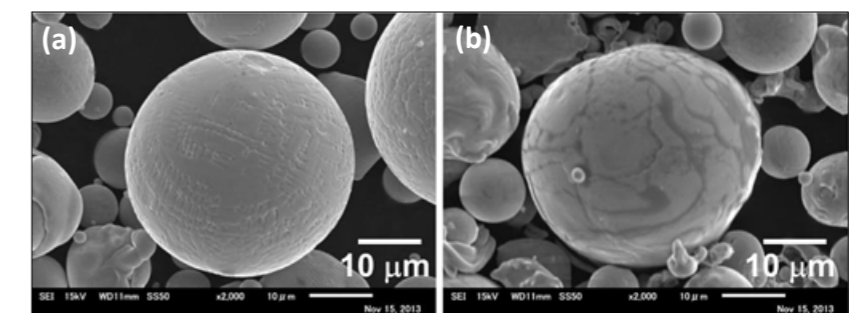

Fig. 1 Scanning electron micrographs of (a) gas and (b) water atomised Co-33Cr-5Mo-0.4N powders [1]

	C content, $C_c$ / mass%	O content, $C_o$ / mass%	N content, $C_n$ / mass%
Gas atomised	0.009	0.029	0.406
Water atomised	0.016	0.150	0.440

Table 1 The C, O and N contents in the gas and water atomised Co-33Cr-5Mo-0.4N powders [1]

	Avalanche angle, $\theta$ / deg	Avalanche energy, $E$ / kJ·kg <sup>-1</sup>	Bulk density, $D_b$ / Mg·m <sup>-3</sup>	Tap density, $D_t$ / Mg·m <sup>-3</sup>
Gas atomised	39.0	16.4	4.92	5.56
Water atomised	52.3	34.3	3.92	4.86

Table 2 The avalanche angle and energy and the bulk and tap densities of the gas and water atomised powders [1]

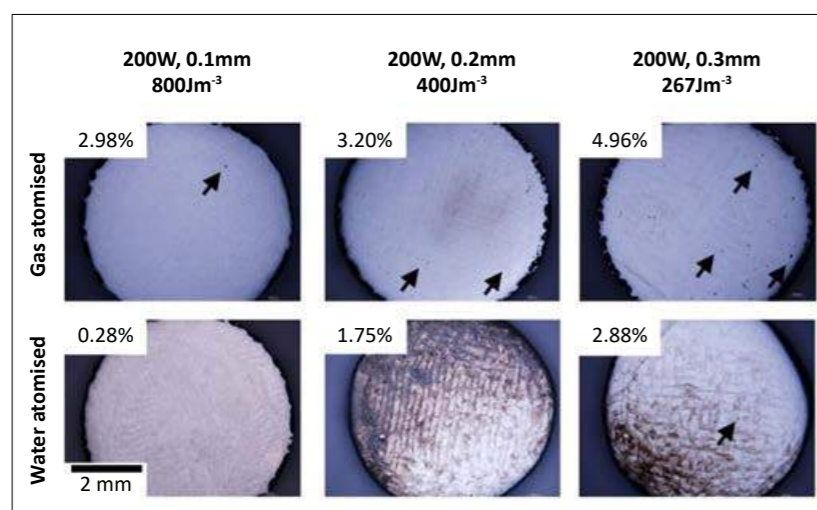

Fig. 2 Optical micrographs of the Co-33Cr-5Mo-0.4N alloy samples built by PBF with the gas and water atomised powders [1]

Elemental mapping of the water atomised powder identified lower levels of Co and Mo at the area with dark contrast on the surface. However, Si and O were enriched at the surface. Si is generally added to Co-Cr-Mo alloys to improve metal flow in casting and was contained in both of the powders. This observation suggests that Si oxides may have formed during the water atomisation process.

Table 1 shows the C, O and N contents in the gas and water atomised powders. The C and N contents were at very similar values in the two powders, but the O content

in the water-atomised powder was about three times higher than that in the gas atomised powder. X-ray diffraction (XRD) profiles for the two powders both showed  $\gamma$  phase peaks, but an absence of  $\epsilon$  phase peaks, confirming that the nitrogen addition had achieved its intended objective in suppressing the martensitic transformation. The calculated lattice parameters were very similar for the two powders at 0.3587 nm and 0.3591 nm for the gas and water atomised powders, respectively. Taking this observation together with the measured higher O content in the water atomised powder

(reported in Table 1), the conclusion was drawn that the oxygen must have been localised at the powder particle surface as oxides and was not in solution in the alloy.

Flowability of the powders was evaluated using a Revolution Powder Analyser from the viewpoint of avalanche angle and energy. These flow characteristics, together with bulk and tap densities, are shown in Table 2.

PBF was performed with both powders using an EOSINT M250 extended machine with a nitrogen atmosphere. The laser power was selected at 150 W or 200 W. Hatching spacing varied from 0.1 mm to 0.3 mm and the laser scan speed and layering thickness were 50 mm/sec and 0.050 mm, respectively. Using these parameters, dumbbell specimens (3 mm in diameter and 18 mm in gauge length) were prepared for tensile tests.

Fig. 2 shows optical micrographs of the Co-33Cr-5Mo-0.4N alloy built by PBF, with the gas- and water-atomised powders, at a range of different energy density levels. Porosity was also indicated in these micrographs. In the samples built by PBF, porosity increased with increasing hatching distance (i.e. decreasing energy density). It should be noted that the porosity of the PBF built sample with the gas atomised powder was higher than that with the water atomised powder. This difference was more apparent at lower energy density.

Fig. 3 shows the mechanical properties of test-pieces built by PBF. The mechanical properties of the builds fabricated with the two powder variants show very similar values at higher energy density. However, with decreasing energy density, the builds with the water atomised powder showed superior mechanical properties, compared with those with the gas atomised powders. The authors have concluded that this difference can be related to the respective porosity levels.

The porosity differences in the PBF builds can be explained with reference to the data in Table 2. The

avalanche angle and energy of the water atomised powder were higher than those of the gas atomised powder. The bulk and tap density of water atomised powder were lower than those of gas atomised powders. These data indicate that the flowability of the water atomised powder was worse than that of gas atomised powder. The lower bulk and tap density means higher porosity in the powder stacked layer and this influences thermal conductivity. Normally, thermal conductivity in a material containing higher porosity is lower than that in one containing lower porosity. When the laser was scanned over these two powders at the same energy level, the temperature rise in the higher porosity layer should be higher than that in the lower porosity layer. In addition, thermal conductivity of SiO<sub>2</sub> is lower than that of the Co-Cr-Mo alloy and therefore the heat transfer in the water-atomised layer may be hindered by the existence of the Si oxide surface layer. Accordingly, the molten pool with the gas atomised powder could be smaller than that with the water atomised powder. Further investigation is underway to test this hypothesis.

Overall, the authors have concluded that the Co-Cr-Mo-N alloy could be successfully built by PBF with either of the two powder variants and that, therefore, the water atomised grade could be regarded as a viable alternative to the gas atomised grade.

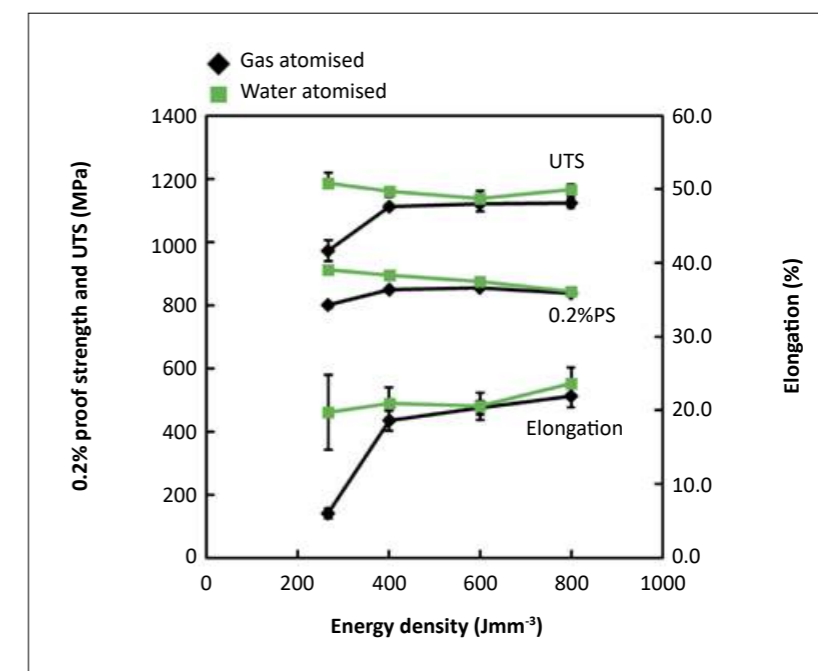

Fig. 3 Mechanical properties of the Co-33Cr-5Mo-0.4N test-pieces built by PBF using gas and water atomised powders [1]

### Additive Manufacturing using water atomised steel powders

The second paper, from Simon Hoeges (GKN Sinter Metals, Germany), Alex Zwirner and Christopher Schade (GKN Hoeganaes, USA), switched the attention to 316L stainless steel powders. The authors stated that at the current status of the technology's development, confidence in the integrity of parts manufactured by AM is based on powder characteristics determined largely by the system manufacturers themselves.

Two most prominent characteristics that dictate high density part fabrication have been defined as being particle size and sphericity.

To achieve these powder characteristics, gas atomisation has emerged as the most widely used method for AM powder production. However, the very strict specifications imposed on powder size, morphology and chemical composition impact powder yield levels and lead to high prices for acceptable powders for AM.

In water atomisation, jetting pressures can be varied in the range between 2000 and 10,000 psi to obtain

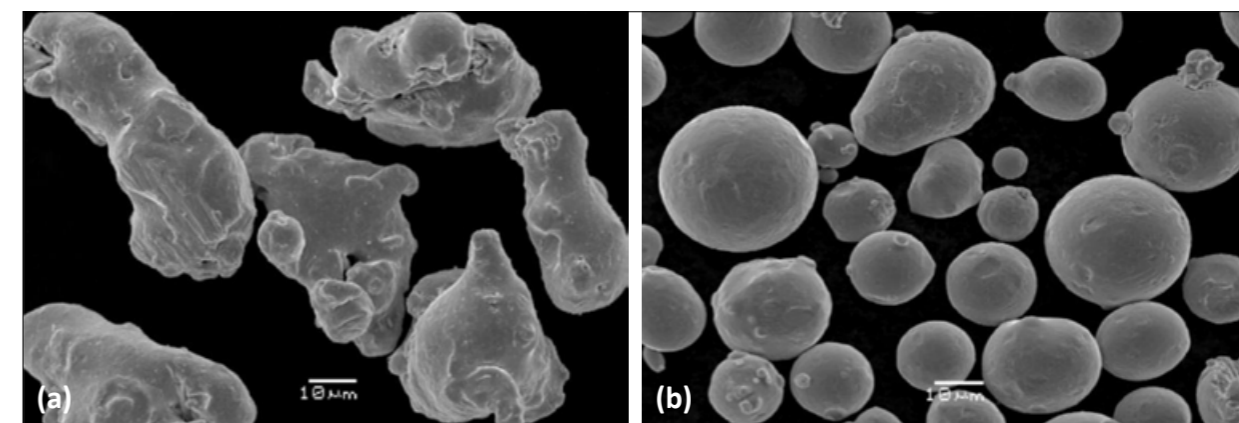

Fig. 4 Morphology of (a) water atomised 316L and (b) gas atomised 316L powder [2]

Type 316L Powder	C	S	O	N	P	Mo	Si	Cr	Ni	Cu	Mn	Fe
Water Atomised	0.012	0.011	0.360	0.025	0.02	2.33	0.89	17.25	12.86	0.03	0.07	66.15
Gas Atomised	0.026	0.006	0.042	0.094	0.02	2.30	0.50	17.10	12.87	0.14	1.31	65.60
Cast	0.03	0.03	0.004	0.080	0.045	2.00-3.00	0.75	16.00-18.00	10.00-14.00	0.30	2.00	remainder

Table 3 Comparison of chemical compositions between water atomised and gas atomised powders and the specified range for cast 316L [2]

desired size ranges and degrees of sphericity. This capability removes the assumed limitations of water atomised powder, in the context of AM, and reduces the differences between water and gas atomised powder to chemical composition

feedstock. Likewise, manganese is not removed in the process, meaning that the raw material must also meet maximum requirements for acceptable content. Controlling the manganese in the raw material is important in reducing the oxidation

from water atomisation can be altered depending on the atomiser's water jetting pressures and the jets' angle to the melt. Changing these parameters can have significant effects on the process yield and on the overall shape of the powder particles.

On the other hand, gas atomisation usually involves melting under a protective atmosphere or in vacuum. This limits the amount of oxidation and nitrogen pick up during the melting process. Due to the fact that oxidation is reduced during the process, there is no longer a strict manganese maximum dictated by the fear of severe oxidation of the metal. The compositional differences, discussed above, are reflected in the respective chemical analyses of the water and gas atomised powder batches reported in the study (Table 3). This table also includes the

**“The product shape from water atomisation can be altered depending on the atomiser's water jetting pressures and the jets' angle to the melt”**

differences, including oxygen levels.

In water atomisation, little refining can occur and certain elements cannot be removed. This means that the carbon in the raw material remains in the final product, facilitating the necessity for low carbon

effects that occur during the water atomisation process.

Water atomised powders tend to be more irregular because the cooling rates in atomisation are 10 to 100 times higher than for gas atomised powders (Fig. 4). The product shape

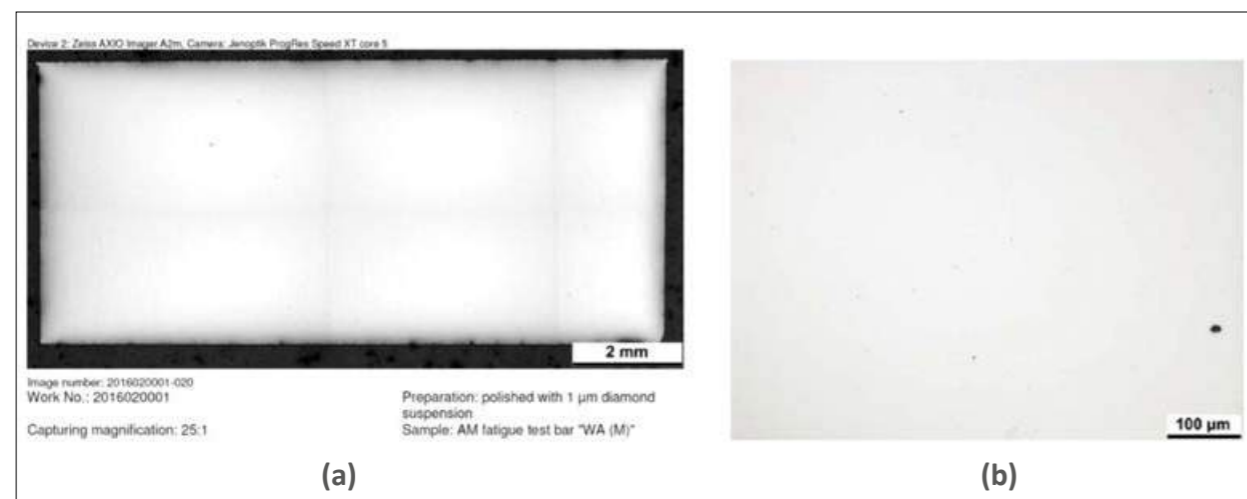

Fig. 5 a) Optical micrograph of the water atomised 316L test piece, processed in the Renishaw AM250 machine, showing porosity b) Optical micrograph of a density cube, produced from the gas atomised powder in the Renishaw AM250 machine, showing porosity [2]

Powder Type	Emod GPa	0.2% Yield MPa	UTS MPa	% Elongation	Hardness (HRB)
WA 316L	150 ± 9	475 ± 16	611 ± 7	32 ± 3	89
GA 316L	147 ± 14	483 ± 26	624 ± 10	34 ± 1	94
ASTMA240 plate, sheet, strip annealed	Not listed	172 min	483 min	40 min	95 max
MIM 316L	193 min	138 min	448 min	40 min	67 min
Cast CF3M1	Not listed	186 min	428 min	30 min	Not listed

Table 4 Mechanical properties of SLM processed water atomised and gas atomised powder parts compared with the specifications for wrought, MIM and cast 316L stainless steel [2]

prescribed compositional specification for a cast 316L stainless steel.

In gas atomisation, the gas to metal ratio is the primary parameter varied to control particle size. The process may also lead to gas becoming entrapped in the metal powder during atomisation, resulting in pores. This is especially noticeable when atomising with argon. Other than particle shape, the second factor influencing powder flowability is the particle size. Finer powders have much more difficulty in flowing due to higher surface areas and Van der Waal's forces, compared with slightly coarser powders. The water atomised powder in this study, WA 316L, had a  $D_{50}$  of 24.40  $\mu\text{m}$  and the gas atomised powder, GA 316L, had a  $D_{50}$  of 32.10  $\mu\text{m}$ . In the context of both powder sphericity and particle size, the water atomised variant would be expected to show lower flowability than the gas atomised powder.

In Selective Laser Melting (SLM), final part density is correlated not only to the process laser power and scan speed, but also to the powder's flowability. If the powder has the ability to spread well and in an unperturbed manner across each build layer, then the presence of porosity should be minimised. Figs. 5a and 5b show porosity images for both a gas atomised powder part and a water atomised powder part, built using a Renishaw AM250 machine.

Even though the flow rate of the water atomised powder is different to that of the gas atomised powder, it has proved possible to modify the process parameters to print nearly fully dense bars of 99.84% relative density in each case. By optimising the laser power, hatch distance, exposure time and several other process parameters, the results

sheet or strip (ASTM A240), for MIM 316L (MPIF Standard 35) and for cast 316L (CF3M), have been included.

The tensile testing results for the SLM-built samples based on gas atomised 316L and water atomised 316L are very close, implying that water atomised powder can closely mimic the expected values from gas atomised powder.

**“The results produced with the water atomised 316L powder can be very comparable with those with the gas atomised powder”**

produced with the water atomised 316L powder can be very comparable with those with the gas atomised powder.

In the reported study, tensile test-pieces were produced from the water and gas atomised powders using the process parameters optimised to achieve full density with each of these powder variants. Each build contained 12 tensile test-pieces with their gauge length in the X-Y plane. Table 4 presents the measured mechanical properties for the test-pieces, built by SLM from each of the powder variants, and, for comparison, the minimum property levels, quoted in the relevant standards for annealed 316L plate,

The achieved strength levels for both SLM variants are substantially higher than the minimum values, quoted in Table 4 for 316L processed by other means. The authors have attributed this difference to the finer microstructures created by the high cooling rates in SLM. The higher strength levels in the SLM materials are accompanied by ductility levels that are lower than the quoted minimum levels for the other process variants, but, at over 30%, must still be regarded as being perfectly adequate for purpose.

Surface roughness can be an issue with SLM produced parts. Currently, however, this issue is not a hindrance to the use of water

atomised powders because post processing is completed on all AM parts regardless of the powder type and its production route.

As stated previously, the SLM process parameters were optimised for the processing of water atomised powder. This alteration of the parameters, in comparison to the parameters for gas atomised powder, may lead to build times being slightly longer. It is currently not known how much the difference in time per part production would be, but, based on the changed parameters in this study, the difference cannot be so significant as to discredit the feasibility of utilising water atomised powder for AM.

The levels of powder flowability represent another area of difference between the two powder variants. In order to facilitate the use of water atomised powders, powder characterisation standards may need to be amended, as more sophisticated testing methods are introduced geared towards powders to be used in AM systems. One such method is the Powder Revolution Analyser. Currently, powders are being neglected for AM use, because of their flowability results from Hall and Carney flow-meters. This may, unfortunately, be eliminating powders, actually capable of being processed by SLM, because of the

powder sizes and their perceived propensity to have poor flow.

The composition of the gas atomised 316L powder falls within the defined range in the ASTM standard (Table 3). However, the composition of the water atomised 316L powder is outside the range in terms of silicon content. However, the silicon contents measured in the SLM produced parts do not, in fact, vary significantly between the water atomised and gas atomised powder variants. The authors postulated that this could be explained by the formation of glassy oxides from silicon and oxygen.

The authors highlighted the issue that varying levels of chemical composition in water and gas atomised powders can play a significant role not only in mechanical properties, but also in corrosion resistance, a very important characteristic that could potentially compromise 316L's utilisation in the medical industry. Biocompatibility applications are heavily reliant on the material's corrosion characteristics, which are not only responsible for the structural stability of the medical component, but also have the potential to lead to the release of Ni, which has been identified as a severe cause of tissue inflammation. This issue, in relation to SLM built 316L parts, is the subject of continuing assessments by the authors.

## References

- [1] Microstructures and mechanical properties of Selective Laser-Melted metals with different processed powder, Naoyuki Nomura *et al*, as presented at the World PM2016 Congress, Hamburg, October 11-14 2016, and published in the Proceedings by EPMA, UK.
- [2] Additive Manufacturing using water atomised steel powders, Simon Hoeges *et al*, as presented at the World PM2016 Congress, Hamburg, October 11-14 2016, and published in the Proceedings by EPMA, UK.

## Author

Dr David Whittaker is a consultant to the Powder Metallurgy industry.  
Tel: +44 (0)1902 338498  
Email: whittakerd4@gmail.com

## Proceedings

The proceedings of the World PM2016 technical sessions and poster programme are published in digital format by the European Powder Metallurgy Association. For more information visit [www.epma.com](http://www.epma.com)

Inovar Communications Ltd

## Sign-up for our metal AM e-newsletter

The *Metal Additive Manufacturing* e-newsletter is sent to more than 13,000 industry professionals worldwide.

Register today to ensure you benefit from reading the latest industry news and advances in metal AM.

You'll also get a link to the latest digital issues of *Metal AM* magazine sent straight to your inbox, free, as soon as they become available.



[www.metal-am.com](http://www.metal-am.com)

13 ▶ 16  
**JUNE**  
**2017**  
LYON - EUREXPO  
FRANCE

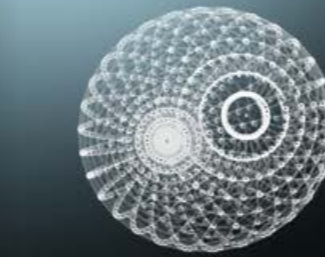

# 3D PRINT

## The event for additive manufacturing

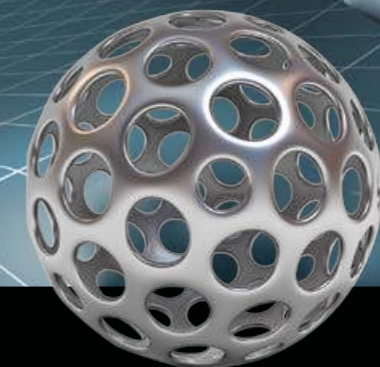
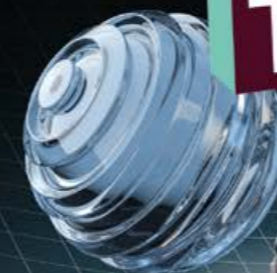

- ▶ A REAL BUSINESS SHOW
- ▶ MULTISECTORAL VISITORS
- ▶ A MULTITUDE OF KEY PLAYERS, ALL FROM ADDITIVE MANUFACTURING TOGETHER IN ONE PLACE: JOIN THEM!

**THE ONLY B TO B SHOW IN FRANCE**  
**EXCLUSIVELY DEVOTED TO ADDITIVE MANUFACTURING**

[3dprint-exhibition.com](http://3dprint-exhibition.com)

REFRACTORY  
METALS

EXPERTISE

HARD  
MATERIALS19 | PLANSEE  
SEMINAR  
2017

Enroll online for the full five-day program:  
[www.plansee-seminar.com](http://www.plansee-seminar.com)

Look forward to over 250 poster presentations and lectures.

More than 500 industry and research experts from 40 nations.

Enjoy stimulating scientific discussions and an exciting social program.

International Conference  
on Refractory Metals  
and Hard Materials

Reutte/Austria  
29 May – 2 June, 2017

**Early bird offer:  
register until 31 March  
and save 12% on  
the registration fee.**

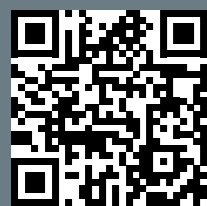

[www.plansee-seminar.com](http://www.plansee-seminar.com)

## Additive Manufacturing at World PM2016: Extending the range of materials in Powder Bed Fusion AM

Within the technical sessions dedicated to Additive Manufacturing research at the World PM2016 Congress a number of papers focused on materials new to Powder Bed Fusion and assessed the ability to process these materials. Dr David Whittaker reviews three papers that report on investigations into Inconel 625 superalloy produced by EBM, Metal Matrix Composites with ceramic reinforcement and the direct metal printing of zinc.

**WORLDPM2016**  
congress and exhibition

### Additive Manufacturing of Inconel 625 superalloy produced by Electron Beam Melting

The first paper selected for review in this article came from Edouard Chauvet, Guilhem Martin, Jean-Jacques Blandin and Remy Dendievel (SIMAP, Grenoble, France) and Benjamin Vayre and Stephane Abed (PolyShape, France) and considered the processing of the nickel-based superalloy, Inconel 625, using Electron Beam Melting (EBM) technology. The authors stated that an increasing demand has emerged from the automotive and aerospace industries to investigate the production of Ni-base superalloy parts using EBM technology. To date, the few reported studies have focussed on microstructure/mechanical property relationships in EBM-processed superalloys, rather than the processing parameters required to produce parts. The reported work was therefore aimed at addressing this shortcoming.

The Inconel 625 powder used in the study was a pre-alloyed material with the nominal chemical composition shown in Table 1 and was produced by argon gas atomisation. Scanning Electron Microscopy (SEM) studies identified that this powder exhibited mainly spherical particles. However, some particle aggregation

and satelliting was also noted. The mean particle density was measured by pycnometry and was found to be equal to  $8.26 \pm 0.17 \text{ g/cm}^3$ . The Inconel 625 density, as reported in the literature, was  $8.44 \text{ g/cm}^3$  and this was used as a reference density for subsequent comparisons. The particles size distribution, as deter-



Fig. 1 The World PM2016 took place at the Congress Centrum Hamburg (©World PM2016 Andrew McLeish)



Element	Ni	Cr	Mo	Fe	Nb	Ti	Al
Wt.%	Bal.	21.52	8.64	3.95	3.51	0.19	0.21

Table 1 Chemical composition in wt.% of the Inconel 625 initial powder [1]

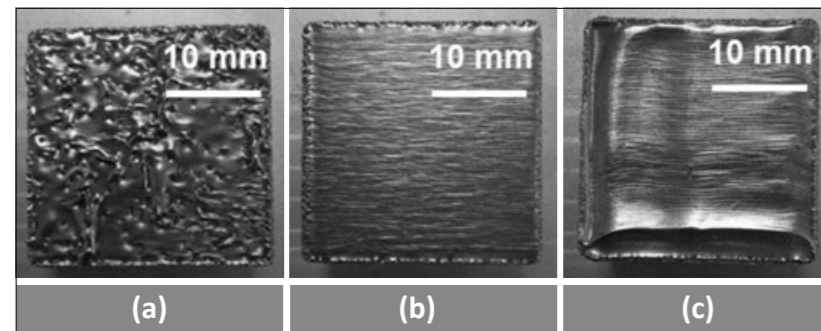

Fig. 2 Typical top surface views of samples fabricated by EBM using the DOE approach: (a) Typical surface view of a porous sample, (b) a Well-Melted sample and (c) an Over-Melted sample [1]

mined by laser granulometry, ranged between 40 and 100  $\mu\text{m}$ . A dendritic microstructure was observed within the particles and also some spherical pores were noted within some of the particles. The authors identified these spherical pores as being entrapped gas from the atomisation process. Entrapped gas pores were observed in about 6% of the powder particles and represented 0.45% porosity in the initial powder.

EBM samples were fabricated using an Arcam A1 system with a building temperature of 900°C. Cube shaped samples (23 x 23 x 25 mm)

were produced. The DOE (Design of Experiment) approach was used to determine the optimum set of parameters. In the melting step, three parameters were varied: speed function (scan speed), beam current and focus offset. The speed function was varied from 20 to 200 (corresponding to a scan speed between 300 and 4500 mm/s), the focus offset was varied from 0 to 50 mA and the beam intensity from 2 to 20 mA. These three parameters were chosen in order to investigate the effects of beam power, beam spot size and melting time. The

pre-heating conditions and scanning strategies were kept constant and the line offset between two scan lines was set at 100  $\mu\text{m}$ .

The built samples showed that different melting parameters led to different top surface morphologies. Based on the top surface morphology, the different samples were classified in three categories (Fig. 2). The porous samples exhibited a porous top surface due to insufficient melting (Fig. 2a). This insufficient melting was attributed to a lack of energy to melt the successive powder layers. The over-melted samples showed a top surface with a high degree of waviness (Fig. 2c). The unevenness results from the melt pool motion caused by higher temperature gradients and surface energy effects. Samples presenting a relatively flat top surface without significant defects were denoted as being well-melted (Fig. 2b).

A map of sample surface quality was plotted as a function of two processing parameters: the Speed Function (proportional to the beam scan speed) and the Focus Offset (related to the beam spot size). For these experiments, a constant Beam Intensity equal to 8 mA was used. Relative densities of the samples were plotted as a function of both Speed Function and Focus Offset. It

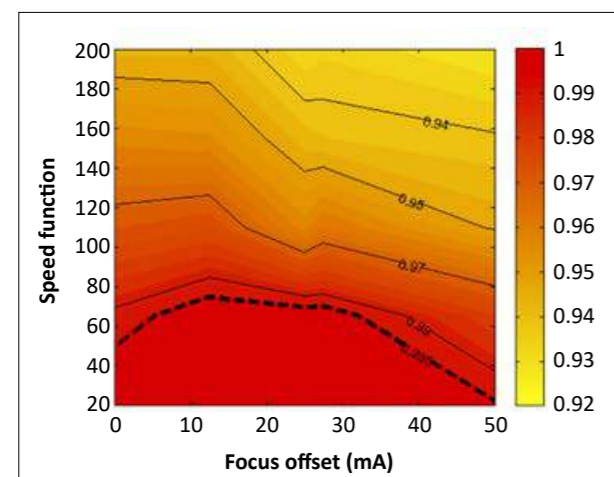

Fig. 3 Surface response based on the relative density obtained from the DOE where the Speed Function and Focus Offset were varied [1]

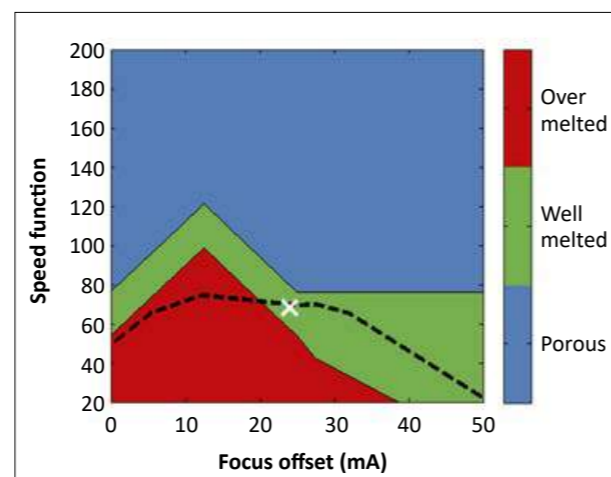

Fig. 4 Process parameter window (in term of Speed Function and Focus Offset) suitable for near fully dense parts. The white cross corresponds to the selected parameters (to produce Inconel 625 parts) [1]

can be seen from Fig. 3 that a higher scan speed and a larger spot size lead to a lower relative density.

The dotted line represents the relative density of the initial powder, around 0.995 because of the internal porosity in the particles. As a result, a sample relative density value lower than 0.995 indicates that the EBM process induced porosity in the material compared to the initial powder. Therefore, a process parameter window, where samples are well-melted with a density higher than or equal to the initial powder density, can be identified (Fig. 4). The well-melted zone exhibits a peak in the lowest range of focus offset. For larger focus offsets, the well-melted zone broadens. This behaviour can be accounted for by the evolution of the beam spot size with the focus offset. Indeed, additional experiments have shown that the sharpest beam spot size was found at a focus offset around 12 mA and not at 0 mA as might have been expected. The authors associated this discrepancy with the calibration of the beam. As a consequence, in the range between 0 and 12 mA (focus offset), the energy input to melt the powder has to be lowered by increasing the scan speed to avoid over-melting. Similarly, for focus offsets larger than 12 mA, the scan speed is decreased to stay in good melting conditions. The larger well-melted zone for focus offsets above 30 mA might be related to the melt pool size (width and depth). With large focus offsets, the melt pool becomes larger and more shallow, but sufficient to melt the powder layers without leaving an un-melted zone.

It should be noted that the limits between each zone have been drawn based only on the observation of the top surface of the samples. Additional investigations are in progress to identify more precisely the different melting zones.

In a second DOE, the scan speed and beam intensity were varied, the Focus Offset being kept constant and equal to 25 mA. A similar classification was used to characterise the top surface morphology of each sample.

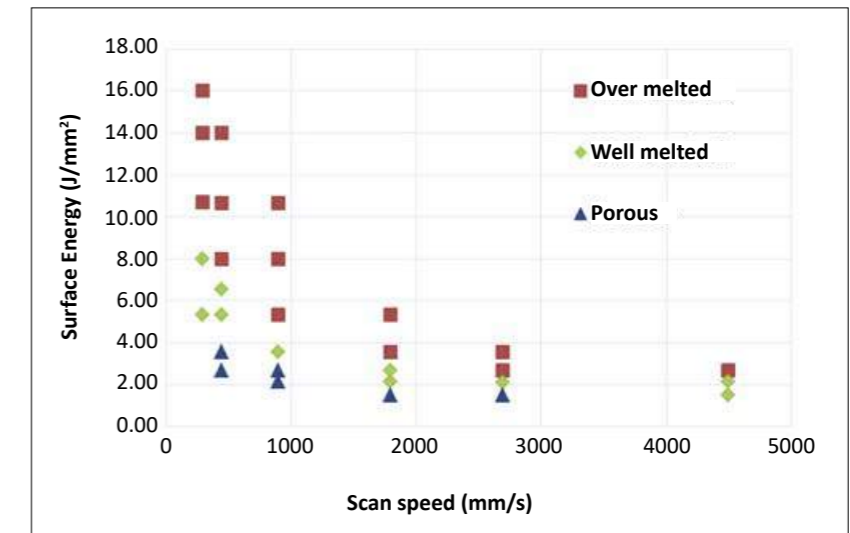

Fig. 5 Process parameter window (in term of Surface Energy and Scan Speed) suitable for well-melted samples [1]

However, the results were plotted as a function of the surface energy  $E_s$  and scan speed. The surface energy to melt the powder is given by the following equation:

$$E_s = \frac{U * I_{beam}}{V_{scan} * \delta_{line\ offset}}$$

where  $U$  is the acceleration voltage (constant in this study and equal to 60 kV),  $I_{beam}$  is the beam intensity (mA),  $V_{scan}$  is the beam scan speed ( $\text{mm}\cdot\text{s}^{-1}$ ) and  $\delta_{line\ offset}$  is the line offset (mm), i.e., the distance between two successive melted lines. A surface energy range to produce well-melted samples can be determined (Fig. 5). The required energy to ensure good melting of the powder layers decreases when the beam scan speed increases. The consequence of increasing the scan speed  $V_{scan}$  is that there is less time for heat losses by conduction between adjacent melt lines. Therefore, the energy required to melt the adjacent line decreases. This representation permits the processing time to be taken into account; a higher scan speed used to melt the samples decreases the melting time and consequently the time to manufacture the parts. In addition, the surface energy required is lower for high scan speed, thus reducing energy costs.

The microstructure of the sample, built using the optimum parameters (Speed Function = 70 and Focus Offset = 25 mA), showed a typical EBM grain structure, where columnar grains containing precipitates in the building direction are observed. The effect of process parameters on microstructure was then investigated. Three samples manufactured under the same conditions using the same scan speed = 900 mm/s and Focus Offset = 25 mA, but with different beam intensities, were characterised. The porous sample showed large levels of porosity because of a lack of melting, with the porosity being measured to be around 5%. The well-melted sample showed only spherical pores, ranging between 2 and 10  $\mu\text{m}$  and most likely the entrapped gas pores already observed in the initial powder. The over-melted sample exhibited a reduced porosity, around 0.2%. This lower content of pores may be explained by a bigger melting pool arising from higher beam intensity. As the melted volume is higher than for the other samples, argon gas bubbles would have more opportunity to escape from the liquid metal during the solidification.

IPF-orientation maps were used to show the effect of the beam intensity on grain microstructure. Where the beam power leads to a

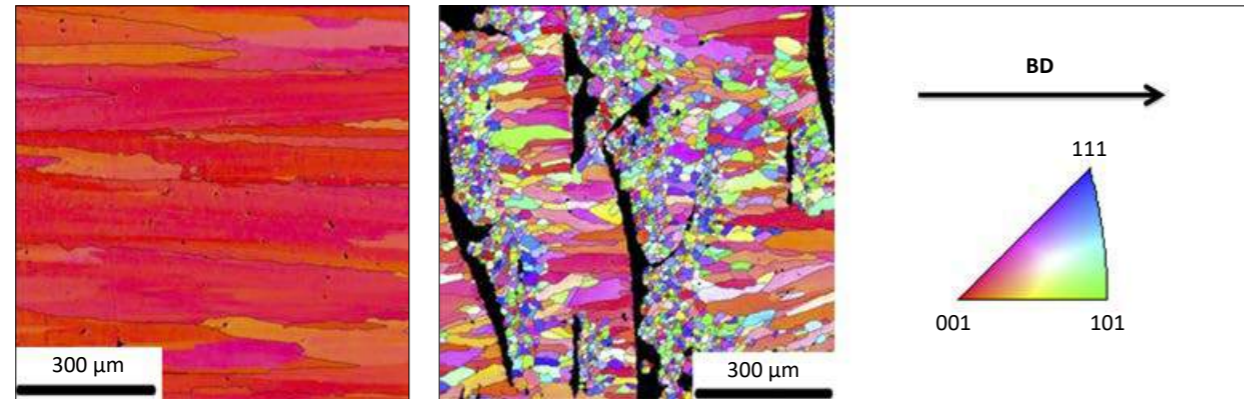

Fig. 6 IPF-map of a well-melted sample (Beam intensity = 5 mA, Scan speed = 900 mm/s and Focus offset = 25 mA) [1]

Fig. 7 EBSD map of a porous sample (Beam intensity = 3 mA, Scan speed = 900 mm/s and Focus offset = 25 mA) [1]

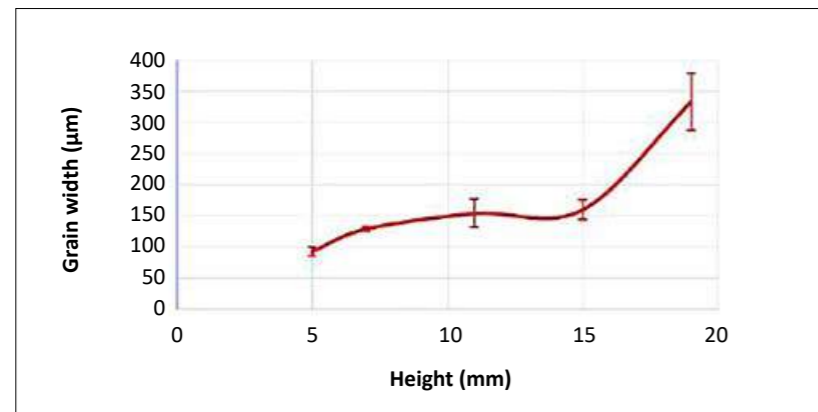

Fig. 8 Columnar grain width variation along an over-melted sample height [1]

well-melted sample, the observed microstructure was a columnar microstructure with strongly textured grains oriented along the Building Direction (with the [001] direction). The columnar grain width was measured to be about 100 µm and was found to be constant all along the sample height, Fig. 6. In the case of porous samples, as illustrated by Fig. 7, small equiaxed grains turned into columnar ones. After porosity induced by a lack of fusion, the grain nucleation took place in the first melted layers and then there was a subsequent epitaxial growth of the grains due to the successive layer melting. The full understanding of this phenomenon will require further, in-depth investigation.

Grains in the over-melted sample exhibited the same texture as those in the well-melted sample but the

grain width varied with the sample height, as shown in Fig. 8. This grain growth selection process results from the higher beam power leading to stronger deviations in the solidification direction. A growth competition between the grains occurs at each layer and, therefore, the grain with the solidification direction deviating least from the build direction grows preferentially.

Overall, the authors concluded that, based on their study, a process parameter window has been identified to produce near full density Inconel 625 parts by EBM, avoiding porosity, due to a lack of melting, and top surface waviness, that a clear correlation between process parameters and sample microstructure (porosity, grain size and texture) has been established and, finally, that the presented results can be used to produce complex EBM parts.

### Selective Laser Melting of steels-based Metal Matrix Composites with ceramic reinforcement

A paper from S Sainz, F Castro and A Veiga (CEIT, Spain) and E Martinez and R Ninerola (AIMME, Spain), addressed the Selective Laser Melting (SLM) of steel-based Metal Matrix Composites (MMCs) with ceramic reinforcement. The authors stated that SLM offers the opportunity to manufacture MMCs that consist of a matrix material, in which a reinforcement material is embedded. However, the reported studies to date have concentrated on MMCs with non-ferrous matrices (Al, Ti and Cu) and information on SLM of steel matrix composites is very scarce. The presented paper, therefore, reported on a set of results obtained in the SLM processing of novel composites based on a 316L stainless steel reinforced by a dispersion of chromium carbides at different weight contents.

The 316L stainless steel powder used in the study had the chemical composition reported in Table 2. The MMCs were obtained by mixing the base powder for four hours with three different amounts of reinforcement: 3, 6 and 9 wt.%. The SLM processing was carried out using a M3 model Concept Laser machine with 100 W power and a spot size of 0.2 mm. The laser scan speed was fixed at 400 mm/s for the

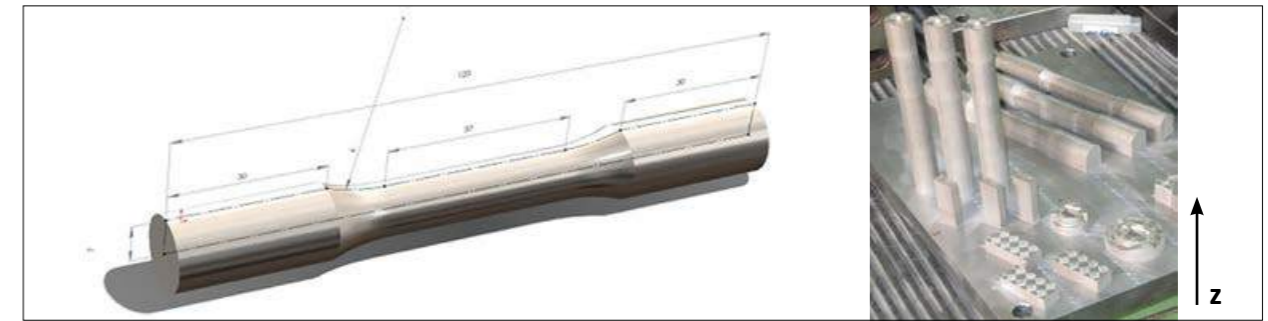

Fig. 9 CAD sketch of a standard tensile testing specimen and image of the SLM processed parts [2]

Steel grade	Cr	Ni	Mo	Si	Mn	V	Co	Cu	C	S	Fe
316L	16.53	11.55	2	0.7	0.54	0.06	0.062	0.029	0.015	0.007	Bal.

Table 2 Chemical composition (wt.%) of the 316L stainless steel used in the study

skin and 500 mm/s for the boundary. The layers were scanned according to a chessboard pattern, establishing an overlap of 0.14 mm between neighbouring stripes inside the same island and 0.026 mm between islands. Tensile specimens were built, with different orientations of their axes with respect to the build direction z (Fig. 9).

Taking the 316L base material as a reference, Fig. 10 provides a comparison of the porosity obtained when adding the ceramic reinforcement at different levels. It can be clearly seen that there is an increase in porosity content obtained when mixing with the chromium carbides, particularly when observing the analysed section in the vertically built

direction samples. The results for the MMC with 9%Cr<sub>3</sub>C<sub>2</sub> were not included in this figure because of crack formation during the manufacturing process of these samples, indicating a limit for this hardening phase, at least for the processing conditions used. Overall, Fig. 10 indicates that the reinforcement material seems to have been homogeneously distributed in the matrix.

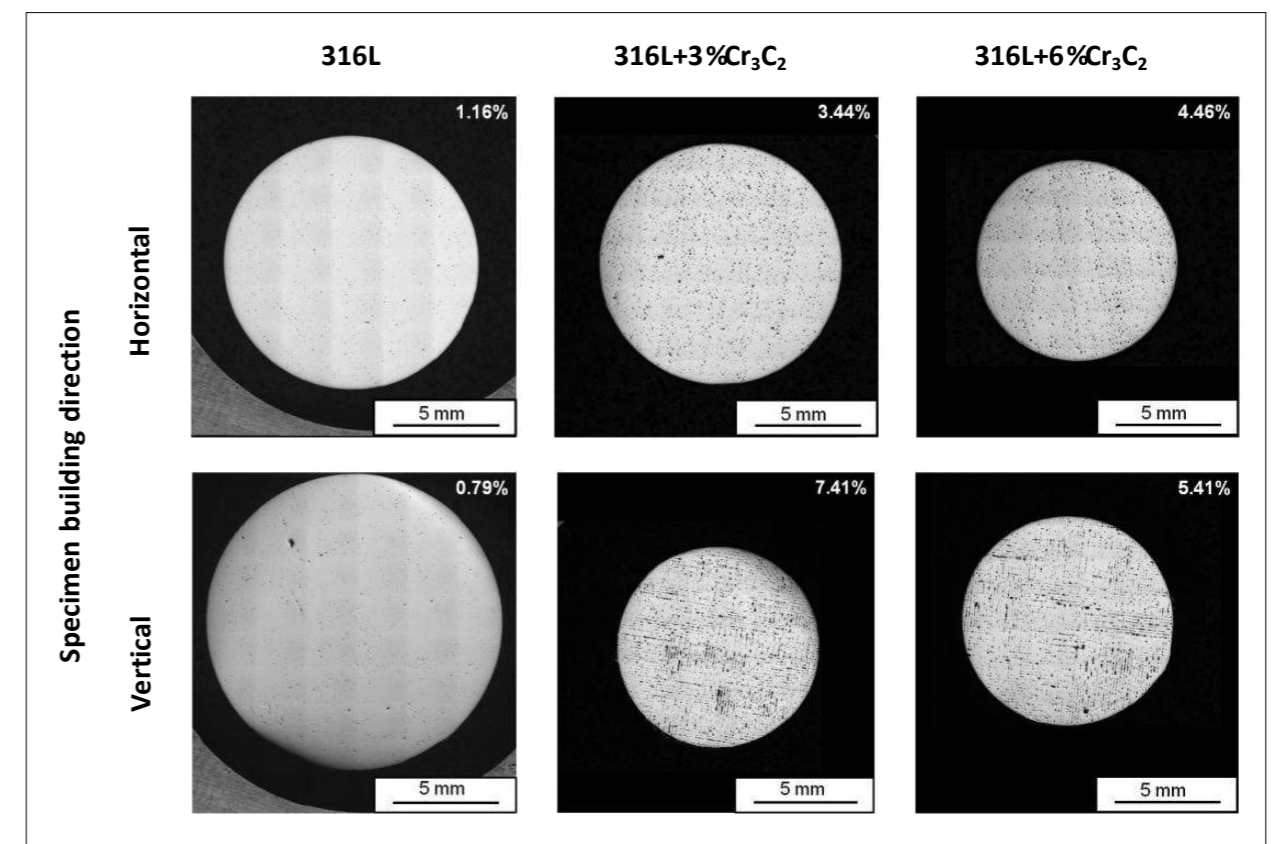

Fig. 10 Optical micrographs and corresponding porosity measurements of MMC tensile specimens [2]

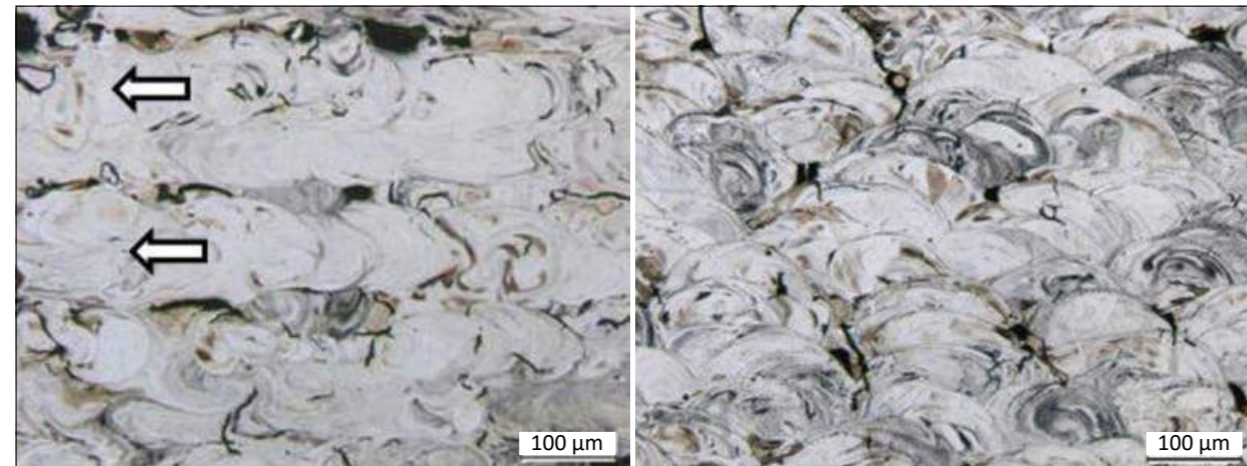

Fig. 11 Cross-sectional microstructures of 316L+3%Cr<sub>3</sub>C<sub>2</sub> tensile samples for (left) vertical and (right) horizontal building directions [2]

Building direction (z)	Material	Yield strength (MPa)	UTS (MPa)	Elongation (%)
VERTICAL	316L	570.0	721.0	34.5
	316L+3 wt%Cr <sub>3</sub> C <sub>2</sub>	645.3	868.3	6.1
	316L+6wt%Cr <sub>3</sub> C <sub>2</sub>	722.2	952.4	3.5
HORIZONTAL	316L	624.0	767.3	31.5
	316L+3 wt% Cr <sub>3</sub> C <sub>2</sub>	794.5	927.3	10.2
	316L+6wt% Cr <sub>3</sub> C <sub>2</sub>	967.7	1155.6	4.7

Table 3 Tensile test results for the MMC materials [2]

The etched microstructure for the 3%Cr<sub>3</sub>C<sub>2</sub>-316L composite material is shown in Fig. 11. On the left side, the scan tracks are distinguishable and the direction followed by the laser is indicated with white arrows in the image.

is bonded onto the other tracks nearby. In terms of porosity, the microstructures illustrate that this is directed and located between layers.

The results of the tensile tests carried out are summarised in

**“Addition of the reinforcement clearly increased strength level significantly”**

the right hand micrograph, where the tensile axis has been built normal to z, the cross-section of the molten scan tracks are visible showing that the stainless steel powder particles were completely fused together within molten and solidified zones having curved edges. The laser tracks overlap, indicating that each molten track

Table 3. Addition of the reinforcement clearly increased strength level significantly and this effect is even more marked when the tensile test-piece axis was built normal to the z direction (presumably related to the lower level of porosity observed in this case). As expected, the opposite effect was observed in terms of elongation.

Fractographic examination indicated ductile fracture for the base 316L material, whereas the addition of Cr<sub>3</sub>C<sub>2</sub> modified the fracture behaviour and presented an intermediate behaviour between ductile and brittle.

The wear behaviour of the various SLM-processed materials was measured using a dry pin-on-disc test method. The tests were performed according to ASTM Standard G99-03, using the following conditions: a chromium steel (60 HRC) pin of 6 mm diameter; a 6 mm friction track diameter; a sliding distance of 1000 m; a speed of 250 RPM; a 10N applied load; a relative humidity less than 35% and room temperature. The friction coefficient was measured during the test and wear was assessed using the wear coefficient  $k$ , ( $k = V/P l$ ) where  $V$  is the volume loss of material,  $P$  the applied load and  $l$  the sliding distance.

Fig. 12 shows the wear behaviour of the materials. Friction coefficients were between 0.6 and 0.7. It is evident that unreinforced 316L stainless steel exhibited a higher volume loss, while the addition of the Cr<sub>3</sub>C<sub>2</sub> particles to the stainless steel matrix was very effective in reducing volume loss during sliding. The best performance was obtained for the 316L+9%Cr<sub>3</sub>C<sub>2</sub> material, as the reinforcing particles had increased the hardness of the composites, as indicated in the table included in the figure.

With a view to illustrating that more complex shape geometries could be built, to take advantage of the freeform technology, some prototypes were prepared as shown in Fig. 13. In this study, the composition with a 6% addition of carbides was selected. On the right of the figure, a gear is presented as an example of a component subjected to stresses and wear, which could be typically found, for example, in the automotive industry. In this sector, a good strength and wear resistance response combined with the lighter structures obtained by this processing technology should be of interest.

Additionally, honeycomb structures (left in Fig. 13) for possible application as catalysts, have also been processed. Being tailor-made, three-dimensional structures of high added value, SLM technology looks to be of great potential value, because of the ability to reduce material wastage significantly. In the SEM images in Fig. 14, the differences in cell size can be appreciated for two of the structures designed. Major concerns in SLM parts are generally residual stresses and distortion. Due to localised heating, complex thermal and phase transformation stresses are generated during the process. In addition, frequent thermal expansion and contraction of the previously solidified layers during fabrication generates considerable thermal stresses and stress gradients that can lead to part distortion or fracture initiation. The cell sizes are reported in Fig. 14 and no significant distinction between the interior and surface locations was found, indicating low levels of distortion. Metallographic examination of the processed honeycombs revealed a fine cellular-dendritic microstructure and epitaxial growth determined by the heat flow.

Based on the built component demonstrators, it was concluded that SLM was a viable route for the manufacture of complex-shaped parts from these stainless steel matrix composites.

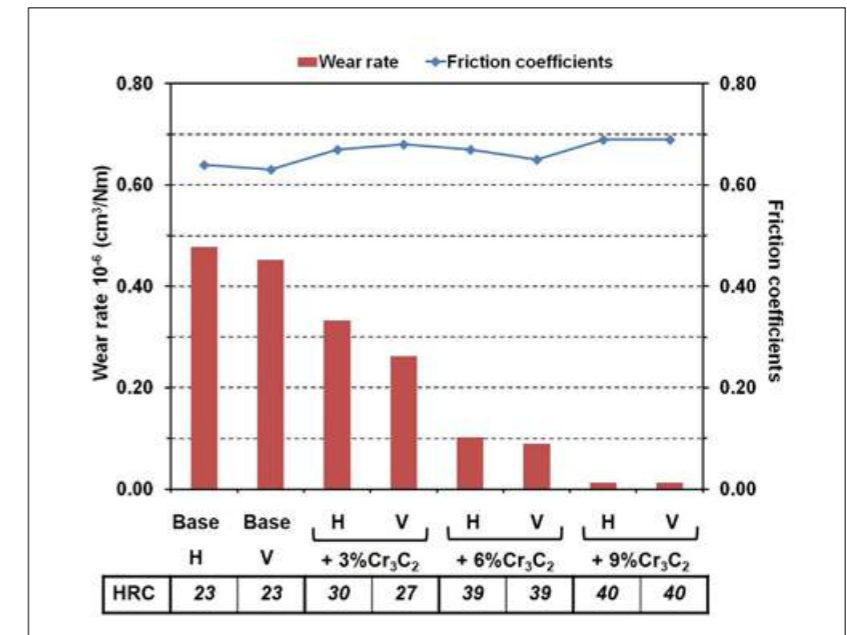

Fig. 12 Wear rates and friction coefficients for the SLM-processed materials [2]

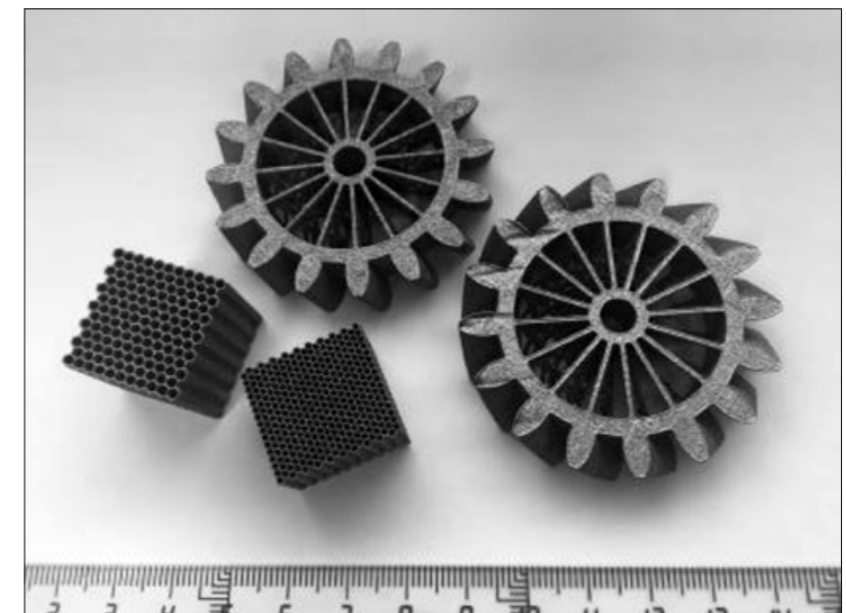

Fig. 13 Prototypes of 316L-6%Cr<sub>3</sub>C<sub>2</sub> processed by SLM [2]

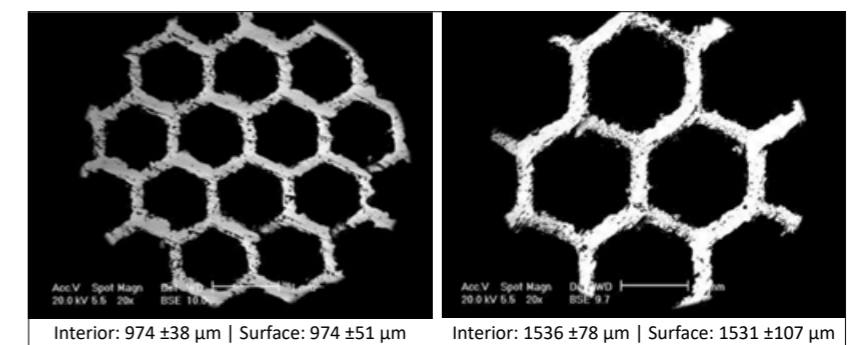

Fig. 14 Details of the cell sizes of two different honeycombs [2]

	D10	D50	D90	Hall flow	O	N	H
	µm	µm	µm	g/s	ppm	ppm	ppm
Powder 1	10	29	58	No flow	2585±71	17±2	23±1
Powder 2	26	39	60	2.38	2551±81	17±2	7.6±0.8

Table 4 Powder characteristics and light element contents for Zn powders P1 and P2 [3]

Power	Scan speed			Unstable melted track
	No melted track			
	0.38 J/mm	0.25 J/mm		
	0.50 J/mm	0.33 J/mm	0.25 J/mm	
0.63 J/mm	0.42 J/mm	0.31 J/mm		

Fig. 15 Single tracks on a Zn plate (no powder) showing that, only for an energy density of 25 J/mm and higher, a stable melted track can be obtained. For high scan speeds, melted tracks become unstable [3]

Power	Scan speed			Unstable melted track
	No melted track			
	0.25 J/mm			
	Too high energy density	0.25 J/mm	0.33 J/mm	
		0.42 J/mm		

Fig. 16 Single tracks on a Zn plate with Zn powder P1 result in a smaller stable region compared to single tracks on a bare Zn plate [see Fig. 15] [3]

### Direct metal printing of zinc: From single laser tracks to high density parts

The Direct Metal Printing (DMP) of zinc was explored in a paper from Karel Lietaert and Lore Thijs (3D Systems, Belgium) and Wouter Baekelant and Jef Vleugels (KU Leuven, Belgium). Zinc alloys have emerged as one of the alloy groups considered promising for biodegradable medical implants and Additive Manufacturing has also emerged as a prime candidate for the building of patient-specific implants. The aim of the reported work was, therefore, the study and development of the DMP process for pure zinc, with particular reference to the influence of process

parameters on the melting, evaporation and solidification of zinc powders.

Two different Zn powders were used in the study. The first (designated P1) was produced by air atomisation and the second (P2) was produced by nitrogen atomisation. Scanning Electron Microscopy (SEM) examination showed the air atomised powder to be clearly less spherical than the nitrogen atomised powder. Sphericity influences powder flowability in a positive way, as it reduces mechanical interlocking between powder particles. Also, the air atomised powder contained more small particles than the nitrogen atomised powder. The larger fraction of small particles in P1 also limits its flowability, because Van der Waals

forces can dominate the gravitational force for small particles. As Table 4 shows, P2 has a better flowability than P1. A good flowability is important as it helps to deposit a uniform powder layer with the scraper blade. All DMP machines with a scraper type deposition system face this limitation. Both powders contained some porosity and the amount of pores was similar for both powders.

Instrumental Gas Analysis (IGA) showed that both powders contained similar amounts of oxygen (Table 4). Oxygen is known to disturb melt pool dynamics in both DMP and laser welding. Given the oxygen content of both powders, this effect is expected to be similar for both. The nitrogen content was also similar for the two powders, while P1 contained more hydrogen than P2. Hydrogen is known to cause pores in aluminium alloys processed by DMP, but the effect for Zn was unknown.

The laser absorptions of P1, P2 and a Ti reference powder were 76%, 73% and 70%, respectively. The authors stated that the difference between P1 and P2 could have been caused, among other parameters, by the differences in particle size distribution, particle shape or surface roughness. The laser absorption of the Zn powders was similar to that of the Ti powder and this shows that Zn is not an unusual material in this respect. The exact value of the laser absorption is, in fact, of limited importance, as the laser energy is mainly absorbed in the liquid melt pool and not the powder bed during DMP.

A customised version of a ProX DMP 320 machine (3D Systems) was used for the DMP experiments. This machine has a maximum laser power of 500 W. For all experiments, a Zn base plate was used, in order to prevent wetting or inter-diffusion problems.

The DMP studies comprised a series of 1D, 2D and 3D experiments. In the 1D experiments, in order to explore the process window for DMP of Zn, single tracks were initially melted along the surface of a bare Zn plate. Stable processing conditions

are generally different for the surface re-melting of bulk materials and powder beds. Therefore, the result of this experiment could only be considered as an estimation of the process window for DMP. A range of laser powers and scan speeds were explored, as shown in Fig. 15. Single tracks were considered stable when a clear, continuous, melted track with surface ripples and a constant track width was obtained. Personal judgment was used to categorise the melted tracks. Fig. 15 shows the process map with indications of the different regions. For stable melted tracks, the energy density (ED) is given.

Next, a similar experiment was repeated on a bed of powder P1 over the Zn plate. The thickness of the first powder layer is difficult to control and the exact thickness value was therefore unknown. Fig. 16 shows the process map with an indication of the different regions. A comparison of Figs. 15 and 16 shows that, with powder, (i) the region without formation of a melted track is smaller, (ii) a new region with excessively high energy density exists and (iii) fewer combinations of laser power and scan speed lead to a stable melted track. The first and second observation can be explained by the higher laser absorption of metal powders compared to bulk metals.

The 2D experiments were aimed at studying material evaporation and, therefore, smoke formation. Laser welding research has shown that vaporised metal forms nanosized particles in the weld plume. Absorption of laser energy by these particles can lead to process instabilities. During DMP, the smoke is removed from the process zone by an inert gas flow. The low melting temperature (694K) and the small difference between melting and boiling temperature (487 K) of Zn promote evaporation. Fig. 17a shows an example of an unstable process, where the absorption of laser power has resulted in a shift from the region with an excessively high energy density to the region without a melted track. This situation was created on

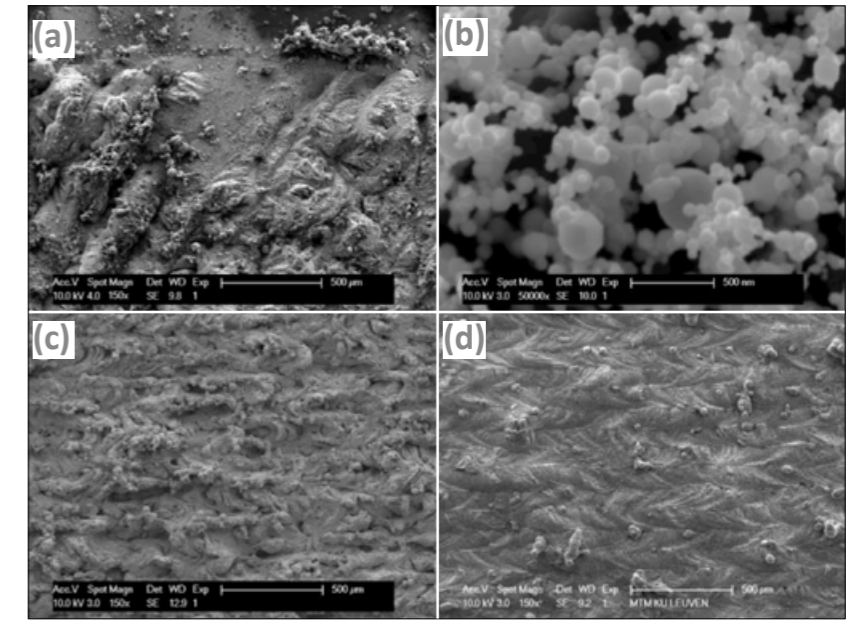

Fig. 17 (a) Excessive smoke formation can lead to an unstable process by variations in the level of laser energy absorption. (b) Smoke consists of 10-500 nm particles. (c) No smooth surface could be obtained with P1 powder. (d) With P2 powder, melted tracks of high quality and sufficient overlap could be obtained [3]

purpose by reducing the gas flow over the powder bed. Fig. 17b shows the nanosized particles that form after Zn evaporation and confirms that the same phenomena, as studied in laser welding, occur during the DMP of Zn.

Scanning a full layer instead of a single vector requires the introduction of an additional parameter, the hatch spacing (distance between two vectors). The choice of the hatch spacing was based on the width of the stable melted tracks obtained in the previous experiments. In order to limit the evaporation of Zn to a level manageable by the gas flow system of the ProX DMP 320, the stable melted track with the lowest linear energy density was chosen (ED=0.25 J/mm). The width of the track was around 165 µm and the hatch spacing should be smaller than the track width to ensure sufficient overlap between different tracks. However, it should not be too small, as this would lead to a high energy input and thus excessive evaporation. A hatch spacing of 100 µm was chosen as a compromise between these two requirements. Fig. 17c shows the result after scanning 25 layers of thickness 30 µm with powder P1. The

result was very different when using powder P2, as shown in Fig. 17d. Fig. 17d shows melted tracks of a good quality, whereas the melted tracks in Fig. 17c look very unstable. As the chemical compositions of the powders were very similar, the difference is more likely caused by powder morphology. The formation of a smooth layer of P1 powder might be possible on a bare plate; however, deposition on a scanned surface is probably more difficult. Even small irregularities of the surface can lead to mechanical interlocking with particles of P1 and disturb powder deposition. This can lead to a different layer thickness at different positions on the build platform and a progressive worsening of surface quality as more and more layers are built. The overlap of the melted tracks in Fig. 17d was deemed to be sufficient, as no porosity between the melted tracks was visible. The authors stated that further investigations will focus on a smaller overlap and a further reduction in smoke formation.

In the 3D experiments, cubes with dimensions 10 x 10 x 10 mm were built. Fig. 18a shows a vertical cross section of such a cube produced

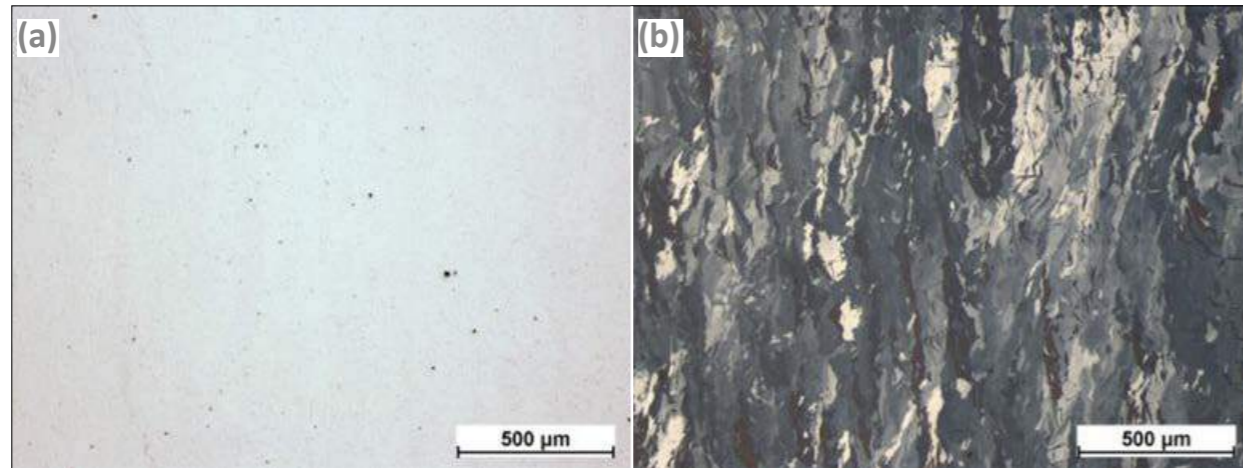

Fig. 18(a) Metallographic analysis shows that a relative density of >99.70% was obtained. (b) Grain growth is mainly parallel to the building direction. Grains grow across multiple layers [3]

with powder P2, using a layer thickness of 30 µm, linear energy density 0.25 J/mm and 100 µm hatch spacing. Despite the small process window caused by the high evaporation tendency, the analysis of this image showed that a relative density >99.70% was obtained. Fig. 18b shows the microstructure of the cross section. A strong texture in the building direction was present. This effect has also been reported for other materials and should have a strong influence on the mechanical properties of the material. The authors indicated that this will be the subject of further research.

The authors concluded by stating that, in order to validate Zn for the production of personalised biodegradable implants, the microstructure, mechanical properties and degradation rate will need to be investigated further.

## References

- [1] Additive Manufacturing of Inconel 625 superalloy produced by Electron Beam Melting, E Chauvet *et al*, as presented at the World PM2016 Congress, Hamburg, October 11-14 2016, and published in the Proceedings by EPMA, UK.
- [2] Selective Laser Melting of Steels-Based Metal Matrix Composites with Ceramic Reinforcement, S Sainz *et al*, as presented at the World PM2016 Congress, Hamburg, October 11-14 2016, and published in the Proceedings by EPMA, UK.
- [3] Direct Metal Printing of Zinc: From Single Laser Tracks to High Density Parts, K Lietaert *et al*, as presented at the World PM2016 Congress, Hamburg, October 11-14 2016, and published in the Proceedings by EPMA, UK.

## Author

Dr David Whittaker is a consultant to the Powder Metallurgy industry. Tel: +44 (0)1902 338498  
Email: whittakerd4@gmail.com

## Proceedings

The proceedings of the World PM2016 technical sessions and poster program are published in digital format by the European Powder Metallurgy Association. For more information visit [www.epma.com](http://www.epma.com)

## Complex, net-shape components in high volumes?

Discover the world of Metal Injection Moulding with *PIM International*

[www.pim-international.com](http://www.pim-international.com)



# industry events

## 2017

### AMUG CONFERENCE 2017

March 19-23, Chicago, USA  
[www.additivemanufacturingusersgroup.com](http://www.additivemanufacturingusersgroup.com)



### 3D Medical Applications

March 30-31, Baltimore, USA  
[healthcareconferencenetwork.com/3d-medical-applications/](http://healthcareconferencenetwork.com/3d-medical-applications/)

### 3D PRINTING: Technology Hub 2017

April 20-22, Milan, Italy  
[www.technologyhub.it/en](http://www.technologyhub.it/en)

### PM CHINA 2017

April 26-28, Shanghai, China  
[www.cn-pmexpo.com/en/](http://www.cn-pmexpo.com/en/)



### Rapid + TCT 2017

May 8-11, Pittsburgh, USA  
[www.rapid3devent.com](http://www.rapid3devent.com)



### EPMA – Additive Manufacturing Seminar

May 18-19, Coventry, United Kingdom  
[seminars.epma.com/am/home](http://seminars.epma.com/am/home)



### 19<sup>th</sup> Plansee Seminar

29 May – 2 June, Reutte, Austria  
[www.plansee-seminar.com](http://www.plansee-seminar.com)



### 6<sup>th</sup> National Congress on Powder Metallurgy 1<sup>st</sup> Ibero-American Powder Metallurgy Congress

June 7-9, Ciudad Real, Spain  
[www.vicnp.es](http://www.vicnp.es)



### AMPM2017 - Additive Manufacturing with Powder Metallurgy Conference

June 13-15, Las Vegas, USA  
[www.ampm2017.org](http://www.ampm2017.org)



### POWDERMET 2017

June 13-15, Las Vegas, USA  
[www.powdermet2017.org](http://www.powdermet2017.org)



### 3D Print Event

June 13-16, Lyon, France  
[www.3dprint-exhibition.com](http://www.3dprint-exhibition.com)



### EMO Hannover 2017

September 18-23, Hannover, Germany  
[www.emo-hannover.de](http://www.emo-hannover.de)



### TCT Show - Birmingham

September 26-28, Birmingham, UK  
[www.tctshow.com](http://www.tctshow.com)



### EURO PM2017 - Congress & Exhibition

October 1-4, Milan, Italy  
[www.europm2017.com](http://www.europm2017.com)



### IN(3D)USTRY - From needs to solutions

October 1-6, Barcelona, Spain  
[www.in3dindustry.com](http://www.in3dindustry.com)

### formnext powered by TCT

November 14-17, Frankfurt, Germany  
[www.formnext.com](http://www.formnext.com)



### Pick up your free copy!

Metal AM magazine is exhibiting at and/or being distributed at events highlighted with the Metal AM cover image

## Event listings and Media Partners

If you would like to see your metal Additive Manufacturing related event listed on this magazine and on our websites, please contact Paul Whittaker:  
email: [paul@inovar-communications.com](mailto:paul@inovar-communications.com)

We welcome enquiries regarding media partnerships and are always interested to discuss opportunities to cooperate with event organisers and associations worldwide.



# advertisers' index

3D Print Exhibition 2017	107	POWDERMET 2017	96
3DEO	11	Praxair Inc.	Inside front cover
19 <sup>th</sup> Plansee Seminar 2017	108	Pressure Technology Inc.	46
AddUp	45	PSI Limited	56
Additive Metal Alloys	31	QuesTek	54
Altair	8	Quintus Technologies	19
AMT	7	Rapid + TCT	89
AMPM2017	82	Renishaw plc	28
AMUG	60	Sandvik Osprey	23
Arcast	50	Sentrol	57
BeAM	49	Simufact	43
Cambridge Sensotec Ltd	41	Sino Europe	47
Carpenter	29	Sintavia, LLC.	37
Centorr Vacuum Industries	22	Smit Röntgen	34
citim	15	Tekna Plasma	26
Concept Laser GmbH	4	Toolcraft	33
Concurrent Technologies Corporation	58	UL	30
Digital Metal / Höganäs AB	6	United States Metal Powders, Inc.	25
Ecka Granules	10	VBN Components	41
ECM	38	Wohlers Associates, Inc.	72
Elcan	21		
Elnik	18		
EMO Hannover 2017	90		
EOS	13		
EPMA Seminars 2017	Outside back cover		
Erasteel	53		
ExOne Company	Inside back cover		
Formnext 2017 powered by TCT	95		
GE Additive	17		
HC Starck	20		
Hoeganaes Corporation	2		
Inert	51		
Kittyhawk	36		
Linear	40		
Material Technology Innovations	35		
Materials Solutions	44		
Metal AM magazine	94/106		
MUT Heating	48		
Nanosteel	16		
Nanoval	55		
NSL	59		
nTopology, Inc.	32		
Oerlikon Metco	39		
Osaka Titanium Technologies	42		
OR Laser	14		
PIM International magazine	118		
PM China	100		

## Advertising opportunities

### **Metal Additive Manufacturing is the magazine for the metal Additive Manufacturing industry**

*Metal Additive Manufacturing* is the business-to-business magazine that focuses on commercial and technical developments in the metal AM industry.

As well as featuring the latest business and applications news, technical developments in the industry will also be highlighted, making the magazine the essential resource for part manufacturers and end-users, along with equipment and material suppliers.

For more information contact Jon Craxford  
Advertising Sales Director, Tel: +44 207 1939 749  
Email: [jon@inovar-communications.com](mailto:jon@inovar-communications.com)



## Advance innovation with **POWDER METAL** 3D PRINTING



### ExOne® Binder Jetting offers:

- Complex parts with high density
- Broad material applications
- Metal injection molding style parts
- Reduced tooling and associated start-up costs



3D Printed 316L Stainless Steel  
for Wicked Grips

## How it works...

Easily produce direct metal  
3D printed parts from CAD using  
ExOne® Systems & Services.



## ExOne supports small businesses.

See ExOne and Wicked Grips present at AMUG:  
March 20, 2017 @ 3:00pm in the ExOne demo suite (D3).

[exone.com](http://exone.com)

Your guide to

## EPMA Seminars, Events & Training 2017

### Hot Isostatic Pressing Seminar

4 - 5 April 2017 | Sheffield, UK

Application Deadline: **1 March 2017**



### Design for PM Seminar

27 - 28 April 2017 | Bologna, Italy

Application Deadline: **22 March 2017**



### Additive Manufacturing Seminar

18 - 19 May 2017 | Coventry, UK

Application Deadline: **18 April 2017**



### Metal Injection Moulding Seminar

1 - 2 June 2017 | Ludwigshafen, Germany

Application Deadline: **4 May 2017**



### EPMA Powder Metallurgy Summer School

19 - 23 June 2017 | Grenoble, France

Application Deadline: **19 April 2017**

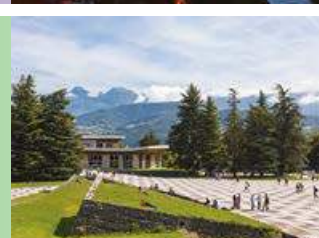

### PM for Non-PM Specialists Seminar

27 - 29 June 2017 | Radevormwald, Germany

Application Deadline: **24 May 2017**



Find out more and apply online today at: [www.epma.com/seminars](http://www.epma.com/seminars)

